

RECOMBINANT DNA SAFETY GUIDELINES, 1990

Department of Biotechnology, Ministry of Science and Technology, Govt. of India

I. INTRODUCTION

The new capabilities to manipulate the genetic material present tremendous potential and find use in many novel experiments and applications. These developments have generated a sense of concern among scientists working in biological areas and others to find ways how safely the research in the field should be carried out and means to regulate work involving pathogenic microorganisms and genes of virulence. Several countries have formulated safety guidelines and regulations for research in the field of recombinant DNA, large scale use of them in production process and their applications in the environment. Considering the possible incremental risks associated with the use of new techniques in laboratory research with pathogenic microorganisms, the National Biotechnology Board issued a set of safety guidelines for India in 1983 to ensure the safety of workers in the laboratory environment. While framing the guidelines, the Committee took into account the local factors such as resistance to infection (immunity), host parasite burden in the community, laboratory environment and chances of survival and growth of altered organisms under the tropical conditions.

Remarkable developments have ensued in the last few years in the field of genetic manipulation and the scenario has shifted from the laboratories to the market place elsewhere. In India there is a growing awareness of the commercial potential of Biotechnology and efforts are being made to promote large scale use of indigenously relevant biotechnologies. A large number of research institutions in Government, Universities and private R&D labs have active biotech programmes where research is being done in both in basic and applied fronts utilising microorganisms plant and animals, tissue culture and cell lines and on development of vaccines towards communicable diseases of both men and animals. A good deal of effort is being made in the areas of diagnostics, biofertilizers, biocides, fertility control, tissue culture of high value crops to develop technologies and useful products. The successes in indigenous research efforts would soon be translated into commercially viable technologies through clearing houses with major R&D Centres, University shops with academic institutions and by the industry itself.

The Biotechnology Safety Guidelines could never be one time exercise as knowledge is ever expanding and the Department of Biotechnology which has the mandate in this area, set up the rDNA Committee to prepare a modified draft on the basis of current scientific information and from the experience gained locally and outside the country on the use of the new technique in the area of research, possible manufacture and applications.

The guidelines cover areas of research involving genetically engineered organism. It also deals with genetic transformation of green plants, rDNA technology in vaccine development and on large scale production and dekliberate/ accidental release of organisms, plants, animals and products derived by rDNA technology into the environment. The issues relating to Genetic Engineering of human embryos, use of embryos and foetuses in research and human germ line gene therapy are excluded from the scope of the guidelines.

While preparing the revised guidelines the Committee and its sub-groups have met 4 times and have taken note of the guidelines currently in use in other countries. The evolution of the guidelines and updation have gone through the process of consultation with experts, academies, agencies and industry and the concerned Ministries with a view to gain general acceptance and broad consensus.

The guidelines are in respect of safety measures for the research activities, large scale use and also the environmental impact during field applications of genetically altered material products.

SCOPE OF THE REVISED GUIDELINES

- 1. Research:** The levels of the risk and the classification of the organisms within these levels based on pathogenicity and local prevalence of diseases and on epidemic causing strains in India are defined in the guidelines. Some of the microorganisms not native to the country have been assigned to a special category requiring highest degree of safety. These include Lassa virus, Yellow fever virus etc. Appropriate practices, equipment and facilities are recommended for necessary safeguards in handling organisms, plants and animals in various risk groups. The guidelines employ the concept of physical and biological containment and also based upon the principle of good laboratory practice (GLP). In this

context, biosafety practices as recommended in the WHO laboratory safety Manual on genetic engineering techniques involving microorganisms of different risk groups have incorporated in the guidelines (Chapter IV).

2. **Large scale operations:** The concern does not diminish when it comes to the use of recombinant organisms scale fermentation operations on large scale fermentation operations or applications of it in the environment. As such, the guidelines prescribe criteria for good large scale practices (GLSP) for using recombinant organisms. These include measures such as proper engineering for containment, quality control, personnel protection, medical surveillance, etc.
3. **Environmental risks:** Application and release of engineered organisms into the environment could lead to ecological consequences and potential risks unless necessary safeguards are taken into account. The guidelines prescribe the criteria for assessment of the ecological aspects on a case by case basis for planned introduction of rDNA organism into the environment. It also suggests regulatory measures to ensure safety for import of genetically engineered materials, plants and animals. The recommendations also cover the various quality control methods needed to establish the safety, purity and efficacy of rDNA products.

II. GUIDELINES

1. **Definition of recombinant DNA:** Recombinant deoxyribonucleic acid (rDNA) by definition involves *in vitro* introduction of different segments of DNA (one being the vector and the others normally unrelated DNA sequences) that are capable of replication in a host cell either autonomously or as an integral part of host's genome and maintenance of their continued propagation. This will include all types of cell fusion, microinjection of DNA or RNA or parts or all of chromosomes, genetic engineering including self cloning and deletion as well as cell hybridation, transformation and other types of virus or pathogen introduction into unnatural hosts.

The organisms involved may belong to these categories:

1.
 - i) Intergeneric organisms
 - ii) Well defined organisms with non-coding regulatory regions
2.
 - i) Biological agents whose source of DNA is a pathogen
 - ii) Organisms that are generally recognised as non-pathogenic and may imbibe the characteristics of a pathogen on genetic manipulation.

2. Classification of a pathogenic microorganisms

- 2.1 The classification of infective microorganisms are drawn up under 4 risk groups in increasing order of risk based on the following parameters:

- pathogenicity of the agent
- modes of transmission and host range of the agent
- availability of effective preventive treatments or curative medicines
- capability to cause diseases to humans/animals/plants
- epidemic causing strains in India

The above mentioned parameters may be influenced by levels of immunity, density and movement of host population, presence of vectors for transmission and standards of environmental hygiene.

An inventory of pathogenic organisms classified in different groups is provided in Chapter V: A1. The scientific considerations for assessment of potential risks in handling of pathogenic organisms include the following:

- i) Characterisation of donor and recipient organisms
- ii) Characterisation of the modified organism
- iii) Expression and properties of the gene product

- 2.2 Based on the risk assessment information, the probability of risk could be further assigned certain quantitative values (Chapter V: A7) for categorisation of experiments in terms of the following:

- i) access factor of the organism

- ii) expression factor of DNA
- iii) damage factor of the Biologically active substance

3. Containment

Containment facilities for different Risk Groups as per the recommendations of World Health Organization (WHO)

The term "Containment" is used in describing the safe methods for managing infectious agents in the laboratory environment where they are being handled or maintained.

Purpose of containment

To reduce exposure of laboratory workers, other persons, and outside environment to potentially hazardous agents.

Types of containment

3.1 **Biological containment (BC):** In consideration of biological containment, the vector (plasmid, organelle, or virus) for the recombinant DNA and the host (bacterial, plant, or animal cell) in which the vector is propagated in the laboratory will be considered together. Any combination of vector and host which is to provide biological containment must be chosen or constructed to limit the infectivity of vector to specific hosts and control the host-vector survival in the environment. These have been categorized into two levels - one permitting standard biological containment and the other even higher that relates to normal and disabled host-vector systems respectively (Chapter V: A3).

3.2 **Physical Containment (PC):** The objective of physical containment is to confine recombinant organisms thereby preventing the exposure of the researcher and the environment to the harmful agents. Physical containment is achieved through the use of i) Laboratory Practice, ii) Containment Equipment, and iii) Special Laboratory Design. The protection of personnel and the immediate laboratory environment from exposure to infectious agents, is provided by good microbiological techniques and the use of appropriate safety equipment, (Primary Containment).

The protection of the environment external to the laboratory from exposure to infectious materials, is provided by a combination of facility design and operational practices, (Secondary Containment).

3.3 **Elements of Containment:** The three elements of containment include laboratory practice and technique, safety equipment and facility design.

i) Laboratory practice and technique:

- Strict adherence to standard microbiological practices and techniques
- Awareness of potential hazards
- Providing/arranging for appropriate training of personnel
- Selection of safety practices in addition to standard laboratory practices if required
- Developing of adopting a biosafety or operations manual which identifies the hazards

ii) Safety equipment (primary barriers): Safety equipment includes biological safety cabinets and a variety of enclosed containers (e.g. safety centrifuge cup). The biological safety cabinet (BSC) is the principal device used to provide containment of infectious aerosols generated by many microbiological procedures. Three types of BSCs (Class I, II, III) are used in microbiological laboratories. Safety equipment also includes items for personal protection such as gloves, coats, gowns, shoe covers, boots, respirators, face shields and safety glasses, etc.

iii) Facility Design (Secondary barriers): The design of the facility is important in providing a barrier to protect persons working in the facility but outside of the laboratory and those in the community from infectious agents which may be accidentally released from the laboratory. There are three types of facility designs: viz, the Basic Laboratory (for Risk Group I and II), the Containment Laboratory (for Risk Group III) and the Maximum Containment Laboratory (for Risk Group IV).

4. **Bio-safety levels:** It consists of a combination of laboratory practices and techniques, safety equipment

and laboratory facilities appropriate for the operations performed and the hazard posed by the infectious agents. The guidelines for Microbiological and Biomedical Laboratories suggest four Biosafety levels in incremental order depending on the nature of work. Additional flexibility in containment levels can be obtained by combination of the physical with the biological barriers. The proposed safety levels for work with recombinant DNA technique take into consideration the source of the donor DNA and its disease-producing potential. These four levels corresponds to (P1<P2<P3<P4) facilities approximate to 4 risk groups assigned for etiologic agents.

These levels and the appropriate conditions are enumerated as follows:

- 4.1 **Biosafety Level 1:** These practices, safety equipment and facilities are appropriate for undergraduate and secondary educational training and teaching laboratories and for other facilities in which work is done with defined and characterised strains of viable microorganisms not known to cause disease in healthy adult human. No special accommodation or equipment is required but the laboratory personnel are required to have specific training and to be supervised by a scientist with general training in microbiology or a related science.
- 4.2 **Biosafety Level 2:** These practices, safety equipment and facilities are applicable in clinical, diagnostic, teaching and other facilities in which work is done with the broad spectrum of indigenous moderate-risk agents present in the community and associated with human disease of varying severity. Laboratory workers are required to have specific training in handling pathogenic agents and to be supervised by competent scientists. Accommodation and facilities including safety cabinets are prescribed, especially for handling large volume are high concentrations of agents when aerosols are likely to be created. Access to the laboratory is controlled.
- 4.3 **Biosafety level 3:** These practices, safety equipment and facilities are applicable to clinical, diagnostic, teaching research or production facilities in which work is done with indigenous or exotic agents where the potential for infection by aerosols is real and the disease may have serious or lethal consequences. Personnel are required to have specific training in work with these agents and to be supervised by scientists experienced in this kind of microbiology. Specially designed laboratories and precautions including the use of safety cabinets are prescribed and the access is strictly controlled.
- 4.4 **Biosafety level 4:** These practices, safety equipment and facilities are applicable to work with dangerous and exotic agents which pose a high individual risk of life-threatening disease. Strict training and supervision are required and the work is done in specially designed laboratories under stringent safety conditions, including the use of safety cabinets and positive pressure personnel suits . Access is strictly limited.

A specially designed suit area may be provided in the facility. Personnel who enter this area wear a one-piece positive pressure suit that is ventilated by a life support system. The life support system is provided with alarms and emergency break-up breathing air tanks. Entry to this area is through an airlock fitted with air tight doors. A chemical shower is provided to decontaminate the surface of the suit before the worker leaves the area. The exhaust air from the suit area is filtered by two sets of HEPA filters installed in the series. A duplicate filtration unit, exhaust fan and an automatically starting emergency power source are provide. The air pressure within the suit area is lower than that of any adjacent area. Emergency lighting and communication systems are provided. All penetrations into the inner shell of the suit area are sealed. A double door autoclave is provided for decontamination of disposable waste materials from the suit area.

5. **Guidelines for rDNA research activities:** The guidelines stipulate three categories of research activities, These are:
 - 5.1 **Category I:** Which are exempt for the purpose of intimation and approval of competent authority.
 - (i) The experiments involving self cloning, using strains and also inter-species cloning belonging to organism in the same exchanger group (Vide Chapter-V A4, A5).
 - (ii) Organelle DNA including those from chloroplasts and mitochondria.
 - (iii) Host-vector systems consisting of cells in culture and vectors, either non-viral or viral containing defective viral genomes (except from cells known to harbour class III, IV and special category etiologic agents listed under Chapter V: A1.
 - 5.2 **Category II:** Those requiring prior intimation of competent authority.

- (i) Experiments falling under containment levels II, III and IV.
- (ii) Experiment wherein DNA or RNA molecules derived from any source except for eukaryotic viral genome may be transferred to any non-human vertebrate or any invertebrate organisms and propagated under conditions of physical containment PC1 and appropriate to organism under study.
- (iii) Experiments involving non pathogen DNA vector systems and regeneration from single cells.
- (iv) Large scale use of recombinants made by self cloning in systems belonging to exempt category (e.g. *E.coli*, *Saccharomyces*, and *B. subtilis*)

5.3 **Category III:** Those requiring review and approval of competent authority before commencement.

- (i) Toxin gene clonings : A list of toxins classified based on their potential toxicity is listed in Chapter V - A6. The number of plasmid toxin gene clonings at present going on are only three viz. *B. subtilis* and *B. sphericus* toxin genes are cloned in *B. subtilis* and cholera toxin genes and *B. thuringiensis* crystal protein genes cloned in *E.coli* K12. These toxins gene cloning are being done under PC1 and BC 1 Containment conditions. All toxin gene cloning experiments producing LD50 less than 50 ug/kg of body weight of vertebrates (Chapter V-A6) or large scale growing may be referred to Institutional Biosafety Committee (IBSC) for clearance.
- (ii) Cloning of genes for vaccine production: e.g. Rinderpest and leprosy antigens. Rinderpest has been classified under Risk Group II in view of the common incidence of the disease in India, though it is listed under special category in the Centres for Disease Control & National Institute of Health (CDC-NIH) system. Similarly, leprosy afflicts a large segment of population which calls for concerted programme to control the disease by vaccination and detection at early stages through immunodiagnostic tests. The containment should be decided by Review Committee on Genetic Manipulation (RCGM) on a case by case basis on experiment utilising DNA from non-defective genomes of organisms recognised as pathogen. In view of no demonstrated risk from handling free *M. laprae* antigens, inactivated whole cells as well as antigens can be assigned to Risk Group I. The details of the rDNA technology in development of vaccines for human and animal health giving containment conditions for observance of safeguards in large scale operations are given in Chapter V-B.
- (iii) Cloning of mosquito and tick DNA experiments should be prescribed on a case by case basis since these are natural vectors for certain endemic viral and parasitic diseases.
- (iv) Genes coding for antibiotic resistance into pathogenic organisms which do not naturally possess such resistance.
- (v) Introduction into cultured human cells of recombinant DNA molecules containing complete genes of potentially oncogenic viruses or transformed cellular genes.
- (vi) Introduction into animal cells of unidentified DNA molecules derived from cancer cells or in vitro transformed cells.
- (vii) Experiments involving the use of infectious animal and plant viruses in tissue culture systems.
- (viii) Experiments involving gene transfer to whole plants and animals.
- (ix) Cell fusion experiments of Animal cells containing sequences from viral vectors if the sequence lead to transmissible infection either directly or indirectly as a result of complementation or recombination in the animals. For experiments involving recombinant DNA of higher class organisms using whole animals will be approved on case by case following IBSC review.
- (x) Transgenesis in animal experiments : Transgenesis method is used to transform animal cells with foreign DNA by using viruses as vectors or by microinjection of DNA into eggs and pre-embryos. The expression of an inserted gene can be influenced both by the regulatory sequences associated with the gene and the sequences present at the site of integration of host genome. At present, there is no way to control where a gene is inserted into the chromosome of either an animal or plant cell. Yet this site of insertion can affect not only the expression of the interested gene but also the regulation of the host cells - DNA e.g. by non-specific activation of cellular protooncogenes.
- (xi) All experiments involving the genetic manipulation of plant pathogens and the use of such genetically manipulated plant pathogens would require approval of competent authority (IBSC).
- (xii) Transfer of genes with known toxicity to plants using *Agrobacterium tumefaciens* or other vectors. Attempts are under way using Ti-plasmid, *A. tumefaciens* and other vectors to transfer toxin-encoding genes that enable plants to make their own insecticide, resist infections or tolerate a variety of environmental stresses. Case by case clearance is needed though exemption may be made for the use of well characterized vectors and non-toxic genes.
- (xiii) In case of plant viruses, permission may be obtained only when it is known that there is a chance of non-species specific spread of infection to plants that could produce changes in pathogenicity, host range or vector transmissibility. The growth of whole plants, propagation of genetically

- manipulated organisms in plants, regeneration of plants from cells transformed by manipulated plant pathogen vector would require containment conditions that are elaborated in Chapter V: C2.
- (xiv) Experiments requiring field testing and release of rDNA engineered microorganisms and plants (Chapter V: C3).
- (xv) Experiments involving engineered microbes with deletions and certain rearrangements.
- (xvi) Diagnostics: No major risk can be foreseen on diagnostics involving in vitro tests. But for diagnostics involving in vivo tests, specific containment levels have to be prescribed on case by case basis. For example, tuberculin moiety could be cloned and used for in vivo hypersensitivity test as a diagnostic method.
- (xvii) Gene therapy for hereditary diseases of genetic disorders.

6. Large scale experiments: Large scale production of bio-molecules from genetically engineered microorganisms have not just been taken up in the country. However, the use of recombinant organisms in large scale operations is expected in the near future.

- 6.1 In the guidelines, experiments beyond 20 litres capacity for research as well as industrial purposes are included in the category of large scale experimentation/operations.
- 6.2 For such activities it is recommended that one should seek approval of the competent authority as described in Chapter-III. In order to seek approval it will be necessary to furnish the relevant details in a prescribed format on the lines suggested by GEAC.
- 6.3 For good large scale practice (GLSP) as well as levels of containment, the following principles of occupational safety and hygiene will be applied.
- i) to keep work place and environment exposure to any physical, chemical or biological agent to the lowest practicable level;
 - ii) to exercise engineering control measures at source and to supplement these with appropriate personal protective clothing and equipment when necessary ;
 - iii) to test adequately and maintain control measures and equipment ;
 - iv) to test when necessary for the presence of viable process organisms outside the primary physical containment ;
 - v) to provide training of personnel
 - vi) to formulate and implement local code of practice for the safety of personnel.
- 6.4 The following safety criteria are to be compiled with for good large scale practice:
- i) The host organism should not be a pathogen, should not contain adventitious agents, and should have an extended history of safe use, or have built-in environmental limitations that permit optimum growth in the bioreactor but limited survival with no adverse consequences in the environment.
 - ii) The vector/insert should be well characterised and free from known harmful sequences; the DNA should be limited in size as much as possible to perform the intended function; should not increase the stability of the recombinant in the environment unless that is a requirement of the intended function; should be poorly mobilisable; and should not transfer any resistance markers to microorganisms not known to acquire them naturally if such acquisition could compromise the use of a drug to control disease agents in human or veterinary medicine or agriculture.
 - iii) The genetically manipulated organism should not be a pathogen and should be assessed as being as safe in the bio-reactor as the host organism, and without adverse consequences in the environment (Chapter V:B2)
- 6.5 The physical containment conditions that should be ensured for large scale experiments and production activities are given in Chapter V: B1.

7. Release to the environment:

- 7.1 Depending on the types of organisms handled and assessment of potential risks involved appropriate containment facilities must be provided to ensure safety of worker and to prevent unwanted release in the environment.

- 7.2 Biowastes resulting from laboratory experiments, in industrial operations should be properly treated so that the pathogenicity of genetically engineered organisms are either destroyed or rendered harmless before disposal in the environment. Special facilities should be created for disposal of experimental animals. All refuse and carcasses must be incinerated. Exemption/relaxation of safety measures on specific cases may be considered based on the risk assessment criteria.
- 7.3 For planned release of organisms into the environment, the following points should be taken into consideration:
- i) Geographical location, size and nature of the site of release and physical and biological proximity to man and other significant biota. In case of plants, proximity to plants which might be cross pollinated.
 - ii) Details of target ecosystem and the predicted effects of release on that ecosystem.
 - iii) Method and amount of release, rate frequency and duration of application.
 - iv) Monitoring capabilities and intentions: how many novel organisms be traced, e.g. to measure effectiveness of application.
 - v) Onsite worker safety procedures and facilities.
 - vi) Contingency plans in event of unanticipated effects of novel organisms.

It is important to evaluate rDNA modified organism for potential risk prior to application in agriculture and environment. Prior to introduction of micro-organisms, properties of the organism, the possible interaction with other disease causing agents and the infected wild plant species should be evaluated. An independent review of potential risks should be conducted on a case by case basis prior to application. Details of points to be taken into account for risk assessment of genetically altered organisms while making proposals for release applications are given at Chapter V:D1. The bio-hazard evaluation of viral, bacterial, insecticidal agents for field applications are provided in Chapter V:C4. Development of organisms for agricultural or environmental applications should be conducted in a stepwise fashion, moving where appropriate, from the laboratory to the growth chamber and green house under containment conditions and good laboratory practice. It should be done under expert advice of competent authority with regard to the area to be covered taking into account the experimental design and condition of isolation. Release of any strain for field testing should be done with the permission of Genetic Engineering Approval Committee (GEAC) as mentioned at Chapter III.

Though, manipulation of plants under containment would not require regulatory clearance of GEAC, testing of altered plant material in the environment however should follow regulatory guidelines seeking experimental field use permit from GEAC even though prima facie, plant material appears safe to test under containment conditions. License for large scale release in case of genetically engineered plants tested pathogens is required.

8. Import and shipment:

- 8.1 The import or receipt of etiologic agents and vectors of human and animal disease or their carriers is subject to the quarantine regulations. Permits authorising the import or receipt of regulated materials for research (e.g. toxin genes, hybridomas, cell cultures, organelle) and specifying conditions under which the agent or vector is shipped, handled and used are issued by the Review Committee on Genetic Manipulation while large scale imports for industrial use are regulated by Genetic Engineering Approval Committee and are mentioned in Chapter III. Safety testing may be required to ensure that it is far from risk.
- 8.2 The Inter-State shipment of indigenous etiologic agents, diagnostic specimens and biologicals products is subject to applicable packaging, labeling and shipping requirements specified for etiologic agents. Packaging and labeling requirements for Inter-state shipment of etiologic agents are summarised and illustrated in the rDNA booklet. All such shipments would need the clearance of Institutional Biosafety Committee mentioned in Chapter III.

9. Quality control of biologicals produced by rDNA technology: The general regulations normally applicable for biologicals are applicable to the recombinant DNA products. The specific relevant aspects to a particular product should be discussed with the appropriate Government Agency on a case by case basis.

- 9.1 A new license for the product or drug application would be required on products made of recombinant DNA technology even if the product is considered to be chemically and physically similar to the naturally occurring substance or previously approved product produced in conventional system.

- 9.2 A recombinant DNA product demonstrated to be identical to normally occurring substance would not require toxicological and pharmacological data if the information is already available at dose levels of intended use but fresh clinical trials will be necessary on all such products.
- 9.3 The booklet prescribes the various control methods needed to establish the safety, purity and efficiency of rDNA products (Chapter V: B4).
- 9.4 Animal feeds: The prevention of food adulteration Act 1954 make it an offence to sell any material for use as a feeding stuff containing any ingredient which is deleterious to animals.

The use of stilbesterol, vitamin B12, antibiotics, direct or indirect sources of nitrogen such as urea and its derivatives, amino acids as additives in forage and animal feed to enhance nutritive effect are in practice. The possibilities of introduction of products derived by biotechnological process such as single cell protein, enzymes and also the growing interest in probiotics i.e. living organisms that are fed to animals to improve performance and use of micro-organisms as silage aids may find means to improve the overall health of animals. The control of these products is the same in principle whether they are produced by chemical or biotechnological process provided the purity criteria are met.

The products derived from animals for human consumption such as meat and milk should be free from any contaminants or residue effect resultant on the use of feed stuffs containing additives produced by biotechnological processes.

Figure 1: Importation and inter state shipment of human pathogens and related materials



Fig.1.1: Diagram illustrate packaging and labeling of etiologic agents in volumes of less than 50 ml.

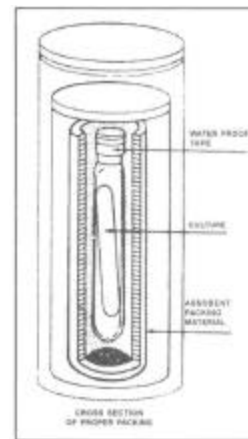

Fig.1.2: Diagram illustrate packaging and labeling of etiologic agents in volumes of less than 50 ml.

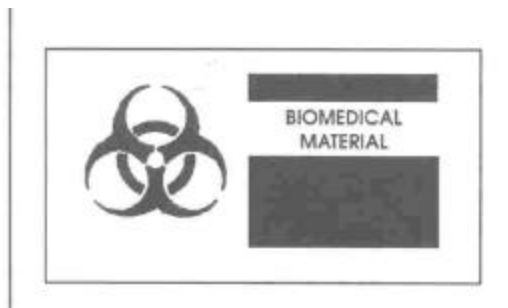

Fig.1.3: Specify the colour and size of the lable which shall be affixed to all etiologic agents. Informating on any provisions of this regulatory requirements may be obtained from Institutional Biosafety Committee (IBSC)

III. MECHANISM OF IMPLEMENTATION OF BIOSAFETY GUIDELINES

For implementation of the guidelines it is necessary to have an institutional mechanism to ensure the compliance of requisite safeguards at various levels. The guidelines prescribe specific actions that include establishing safety procedures for rDNA research, production and release to the environment and setting up containment conditions for certain experiments. The guidelines suggest compliance of the safeguards through voluntary as well as regulatory approach. In this connection, it is proposed to have a mechanism of advisory and regulatory bodies to deal with the specific and discretionary actions on the following:

- a. Self regulation and control in the form of guidelines on recombinant research activities; and
- b. Regulation of large scale use of engineered organisms in production activity and release of organisms in environmental applications under statutory provisions.

The institutional mechanism as proposed for implementation of guidelines is shown in organogram in Figure 2. Mainly it consists of the following:-

- i) Recombinant DNA Advisory Committee (RDAC)
- ii) Institutional Biosafety Committee (IBSC)
- iii) Review Committee on Genetic Manipulation (RCGM)
- iv) Genetic Engineering Approval Committee (GEAC)

Scope and functions of advisory committee and statutory body

1. **Recombinant DNA Advisory Committee (RDAC):** The Committee should take note of developments at national and international levels in Biotechnology towards the currentness of the safety regulation for India on recombinant research use and applications. It would meet once in 6 months or sooner for this purpose.

The specific terms of reference for Recombinant Advisory Committee include the following :

- i) To evolve long term policy for research and development in Recombinant DNA research.
- ii) To formulate the safety guidelines for Recombinant DNA Research to be followed in India.
- iii) To recommended type of training programme for technicians and research fellows for making them adequately aware of hazards and risks involved in recombinant DNA research and methods of avoiding it.

2. Implementation Committees:

2.1 Institutional Biosafety Committee (IBSC)

Institutional Biosafety Committee (IBSC) are to be constituted in all centres engaged in genetic engineering research and production activities. The Committee will constitute the following:

- (i) Head of the Institution or nominee
- (ii) 3 or more scientists engaged in DNA work or molecular biology with an outside expert in the relevant discipline.
- (iii) A member with medical qualifications - Biosafety Officer (in case of work with pathogenic agents/large scale use).
- (iv) One member nominated by DBT.

- 2.2 The Institutional Biosafety Committee shall be the nodal point for interaction within institution for implementation of the guidelines. Any research project which is likely to have biohazard potential (as envisaged by the guidelines) during the execution stage or which involve the production of either microorganisms or biologically active molecules that might cause bio-hazard should be notified to IBSC. IBSC will allow genetic engineering activity on classified organisms only at places where such work should be performed as per guidelines. Provision of suitable safe storage facility of donor, vectors, recipients and other materials involved in experimental work should be made and may be subjected to inspection on accountability.

The biosafety functions and activity include the following:

- i) Registration of Bio-safety Committee membership composition with RCGM and submission of reports.
IBSC will provide half yearly report on the ongoing projects to RCGM regarding the observance of the safety guidelines on accidents, risks and on deviations if any. A computerised Central Registry for collation of periodic report on approved projects will be set up with RCGM to monitor compliance on safeguards as stipulated in the guidelines.
- ii) Review and clearance of project proposals falling under restricted category that meets the requirements under the guidelines.
IBSC would make efforts to issue clearance quickly on receiving the research proposals from investigators.
- iii) Tailoring biosafety programme to the level of risk assessment.
- iv) Training of personnel on biosafety.
- v) Instituting health monitoring programme for laboratory personnel.

Complete medical check-up of personnel working in projects involving work with potentially dangerous microorganisms should be done prior to starting such projects. Follow up medical checkups including pathological tests should be done periodically, at least annually for scientific workers involved in such projects. Their medical records should be accessible to the RCGM. It will provide half yearly reports on the ongoing projects to RCGM regarding the observance of the safety guidelines on accidents, risks and on deviations if any.

- vi) Adopting emergency plans.

3. Review Committee on Genetic Manipulation (RCGM): The RCGM will have the following composition:

- i) Department of Biotechnology
- ii) Indian Council of Medical Research
- iii) Indian Council of Agricultural Research
- iv) Council of Scientific & Industrial Research
- v) Three Experts in Individual capacity
- vi) Department of Science & Technology

The RCGM will have the functions:

- i) To establish procedural guidance manual - procedure for regulatory process with respect to activity involving genetically engineered organisms in research, production and applications related to environmental safety.
- ii) To review the reports in all approved ongoing research projects involving high risk category and controlled field experiments, to ensure that safeguards are maintained as per guidelines.
- iii) To recommend the type of containment facility and the special containment conditions to be followed for experimental trials and for certain experiments.
- iv) To advise customs authorities on import of biologically active material, genetically engineered substances or products and on excisable items to Central Revenue and Excise.
- v) To assist Department of Industrial Development, Banks towards clearance of applications in setting up industries based on genetically engineered organisms.
- vi) To assist the Bureau of Indian Standards to evolve standards for biologics produced by rDNA technology.
- vii) To advise on intellectual property rights with respect to rDNA technology on patents.

3.1 The RCGM would have a Research Monitoring function by a group consisting of a smaller number of individuals (3 or 4). The monitoring group would be empowered to visit experimental facilities in any laboratory in India where experiments with biohazard potential are being pursued in order to determine the Good Laboratory practice and conditions of safety are observed.

3.2 In addition, if the RCGM has reasons to believe that there is either actual or potential danger involved in the work carried out by any laboratory (which might or might not have obtained prior clearance for the project), the monitoring group would be empowered to inspect the facility and assess the cause of any real or potential hazard to make appropriate recommendation to the RCGM. RCGM would be empowered to recommend alteration of the course of experiments based on hazard considerations or

take steps to cancel the project grant, in case of deliberate negligence and to recommend appropriate actions under the provisions of Environmental Protection Act (EPA) where necessary.

- 4. Genetic Engineering Approval Committee (GEAC):** Genetic Engineering Approval Committee (GEAC) will function under the Department of Environment (DOEn) as statutory body for review and approval of activities involving large scale use of genetically engineered organisms and their products in research and development, industrial production, environmental release and field applications.

The functions include giving approval from environmental angle on:

- i) Import, export, transport, manufacture, process, selling of any microorganisms or genetically engineered substances or cells including food stuffs and additives that contains products derived by Gene Therapy.
- ii) Discharge of Genetically engineered/classified organisms/cells from Laboratory, hospitals and related areas into environment.
- iii) Large scale use of genetically engineered organisms/classified microorganisms in industrial production and applications. (Production shall not be commenced without approval).
- iv) Deliberate release of genetically engineered organisms. The approval will be for a period of 4 years.

The composition of the Committee would be as follows:

1. Chairman - Additional Secretary, Department of Environment
Co-Chairman - Expert Nominee of Secretary, DBT.
 2. Representatives of concerned Agencies and Departments:
 - Ministry of Industrial Development
 - Department of Science & Technology
 - Department of Ocean Development
 - Department of Biotechnology
 3. Expert Members:
 - Director-General, Indian Council of Agricultural Research
 - Director General, Indian Council of Medical Research
 - Director-General, Council of Scientific & Industrial Research
 - Director-General, Health Services (Ministry of Health & Family Welfare)
 - Plant Protection Adviser (Ministry of Agriculture)
 - Chairman, Central Pollution Control Board
 - 3 Outside experts in individual capacity.
 4. Member Secretary - Official of, DOEn
- 4.1 GEAC will have the Biotechnology Coordination Committees under it which will functions as legal and statutory body with judicial powers to inspect, investigate and take punitive action in case of violations of statutory provisions under EPA.
- i) Review and control of safety measures adopted while handling large scale use of genetically engineered organisms/classified organisms in research, developmental and industrial production activities.
 - ii) Monitoring of large scale release of engineered organisms/products into environment, oversee field applications and experimental field trials.
 - iii) To provide information/data inputs to RCGM upon surveillance of approved projects under industrial production, and in case of environmental releases with respect to safety, risks and accidents.
- 4.2 Statutory rules and regulations to be operated by the GEAC would be laid down under the Environment Protection Act, 1986.

5. Funding Agency

- 5.1 The funding agency will be responsible for approval and clearing of research proposals for grants in aid in respect of rDNA research activities. The funding agency at the centre and state level will be advised to ensure that the guidelines are taken into account for compliance while supporting grants on research projects. Investigators will be required to submit as part of the project application an evaluation of biohazards that may arise and also the requirement on the type of containment facility, certified by IBSC. The funding agency should state clearly that support on approved projects will be withdrawn in case of deliberate violation or avoidable negligence of the rDNA guidelines. The investigators will also be asked to make a declaration in their publications that the work was carried out following the national guidelines. The funding agency will annually submit to RCGM the list of approved projects that come under high risk categories.
- 5.2 The concerned institutions will be instructed to the effect that initiation and execution of any research project, production activity and field trials should be preceded by necessary procedures of notification and approval of the competent authority including IBSC, GEAC depending on the nature of projects and activities.
6. Initially, to familiarize the R&D groups in industry and other institutions the guidelines will be widely publicised through scientific journals and popular science magazines. Workshops and group discussions will be organised in R&D institutes, and other places to fulfill the need for public information on safety aspects of rDNA technology. Steps will be taken to introduce courses in biohazards and safety procedures for personnel working in areas which are likely to involve biohazards as part of the training programme.

Figure 2: Institutional mechanism for implementation of guidelines frame work for implementation

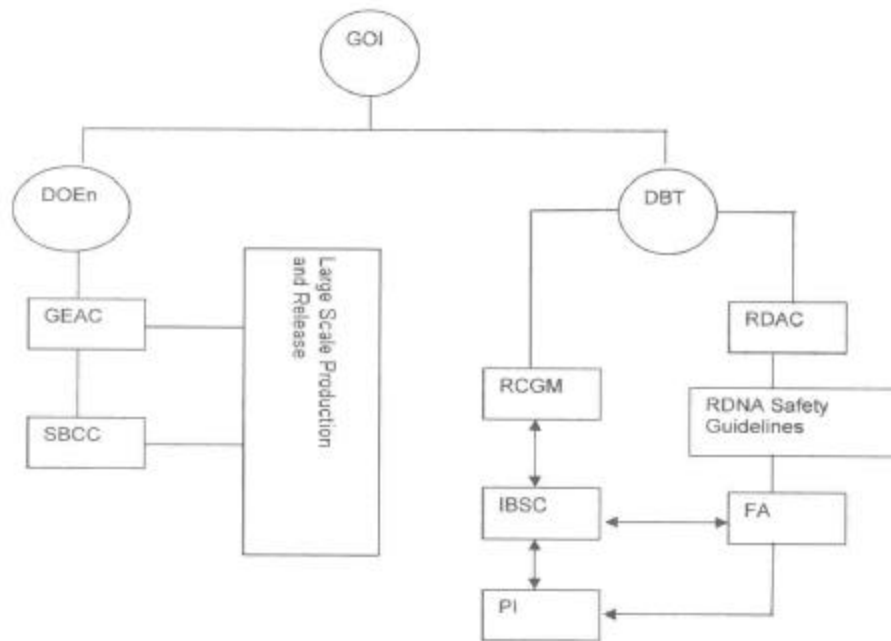

GOI	-	Government of India
DBT	-	Department of Biotechnology
RDAC	-	Recombinant DNA Advisory Committee
IBSC	-	Institutional Biosafety Committee
RCGM	-	Review Committee on Genetic Manipulation
DOEn	-	Department of Environment
GEAC	-	Genetic Engineering Approval Committee
SBCC	-	State Biotechnology Coordination Committee
PI	-	Principal Investigator (R&D/Industry/Others)
FA	-	Funding Agency (Govt./Private & Public Institutions)

IV. CONTAINMENT FACILITIES AND BIOSAFETY PRACTICES:

A. The Basic Laboratory: The basic laboratory encompasses all laboratories working with Risk Group I and Risk Group II agents-those that present low or moderate risk to the laboratory worker and low or limited risk to the community. In some instances, particularly in clinical laboratories of hospitals, exposure to agents of high individual risk may occasionally or unexpectedly occur in the course of routine work. These possibilities must be recognised in developing safety plans and policies.

The basic laboratory guidelines presented here are comprehensive and detailed as they are fundamental to all classes of laboratory. The guidelines for containment laboratories that follow later are modifications of the basic guidelines designed for work with the more dangerous pathogens.

Code of practice: This code is a listing of the most essential laboratory procedures that are basic to safe laboratory practice. In many laboratories and national laboratory programmes, such a code may be given the status of "rules" for laboratory operations. In these guidelines various parts of the "code of practice" will be elaborated and explained.

It is emphasised that good laboratory practice is fundamental to laboratory safety and cannot be replaced by specialised equipment, which can only supplement it.

The most important rules are listed below, not necessarily in order of importance :

1. Mouth pipetting should be prohibited.
2. Eating, drinking, smoking, storing food, and applying cosmetics should not be permitted in the laboratory work area.
3. The laboratory should be kept neat, clean and free of materials not pertinent to the work.
4. Work surfaces should be decontaminated at least once a day and after any spill of potentially dangerous material.
5. Members of the staff should wash their hands after handling infectious materials and animals and when leaving the laboratory.
6. All technical procedures should be performed in a way that minimizes the creation of aerosols.
7. All contaminated liquid or solid materials should be decontaminated before disposal or reuse; contaminated materials that are to be autoclaved or incinerated at a site away from the laboratory should be placed in durable leakproof containers, which are closed before being removed from the laboratory.
8. Laboratory coats, gowns, or uniforms should be worn in the laboratory; laboratory clothing should not be worn in non laboratory areas; contaminated clothing should be disinfected by appropriate means.
9. Safety glasses, face shields, or other protective devices should be worn when necessary to protect the eyes and face from splashes and impacting objects.
* Laboratory Biosafety Manual (Geneva) World Health Organisation, (1983)
10. Only persons who have been advised of the potential hazards and meet any specific entry requirements (e.g. immunization) should be allowed to enter the laboratory working areas; laboratory doors would be kept closed when work is in progress; access to animal houses should be restricted to authorized persons; children are not permitted in laboratory working areas.
11. There should be an insect and rodent control programme.
12. Animals not involved in the work being performed should not be permitted in the laboratory.
13. The use of hypodermic needles and syringes should be restricted to parenteral injection and aspiration of fluids from laboratory animals and diaphragm vaccine bottles. * Laboratory Biosafety Manual (Geneva) World Health Organisation, (1983) Hypodermic needles and syringes should not be used as a substitute for automatic pipetting devices in the manipulation of infectious fluids. Cannulas should be used instead of sharp needles wherever possible.
14. Gloves should be worn for all procedures that may involve accidental direct contact with blood, infectious materials, or infected animals. Gloves should be removed aseptically and autoclaved with other laboratory wastes before disposal. When disposable gloves are not available, re-usable gloves should be used. Upon removal they should be cleaned and disinfected before re-use.

15. All spills, accidents and overt or potential exposures to infectious materials should be reported immediately to the laboratory supervisor. A written record should be prepared and maintained. Appropriate medical evaluation, surveillance, and treatment should be provided.
16. Baseline serum samples may be collected from and stored for all laboratory and other at risk personnel. Additional serum specimens may be collected periodically depending on the agents handled or the function of the facility.
17. The laboratory supervisor should ensure that training in laboratory safety is provided. A safety or operations manual that identifies known and potential hazards and that specifies practices and procedures to minimise or eliminate such risks should be adopted. Personnel should be advised of special hazards and required to read and follow standard practices and procedures.

Laboratory design and facilities: In designing a laboratory and assigning certain types of work to a laboratory, special attention should be paid to conditions that are known to pose problems. These include :

- creation of aerosols;
- work with large volumes and/or high concentration of microorganisms;
- overcrowded, overequipped laboratories;
- infestation with rodents or insects;
- unauthorised entrance.

Design features for basic laboratories:

1. Ample space must be provided for the safe conduct of laboratory procedures.
2. Walls, ceiling, and floors should be smooth, easily cleanable, impermeable to liquids, and resistant to the chemicals and disinfectants normally used in the laboratory. Floors should be slip resistant. Exposed pipes and ducting should stand clear of walls. (Horizontal runs should be avoided to prevent dust collection.)
3. Adequate illumination should be ensured for carrying out all activities. Undesirable reflection is to be avoided.
4. Bench tops should be impervious to water and resistant to disinfectants, acids, alkalis, organic solvents, and moderate heat.
5. Laboratory furniture should be sturdy, and open spaces between and under benches, cabinets, and equipment should be accessible for cleaning.
6. Storage space must be adequate to hold supplies for immediate use and thus prevent clutter on bench tops and in the aisles. Additional long-term storage space, conveniently located outside and working areas, should also be provided.
7. Wash-basins, with running water if possible, should be provided in each laboratory room, preferably near the exit.
8. Doors should have appropriate fire ratings, be self-closing, and have vision panels.
9. An autoclave (or a suitable substitute) for decontamination of infectious laboratory wastes should be available in the same building as the laboratory.
10. Facilities for storing outer garments and personal items and for eating, drinking and smoking should be provided outside the working areas.
11. There are no specific ventilation requirements. In planning new facilities, consideration should be given for providing a mechanical ventilation system that provides an inward air flow and exhaust without recirculation. If there is no mechanical ventilation, windows should be openable, preferably having flyproof screens. Skylights should be avoided.
12. Space and facilities should be provided for the safe handling and storage of solvents, radioactive materials, and compressed gases.
13. Safety systems should cover fire, electrical emergencies, emergency shower, and eyewash facilities.
14. First-aid areas or rooms suitably equipped and readily accessible should be available.
15. A good-quality and dependable water supply is essential. There should be no cross-connections between sources for laboratory purposes and the drinking water supply. The public water system must be protected by a back-flow preventer.

16. A reliable electricity supply with adequate capacity should be available. There should be emergency lighting to permit safe exit. A standby generator with automatic cut-off is desirable for the support of essential equipment-incubators, freezers, etc. In particular, it is indispensable for the ventilation of animal cages.
17. A reliable supply of town, natural or bottled gas to each working area is essential. Good maintenance of the installation is mandatory.
18. Three aspects of waste disposal need special attention to meet performance and/or pollution control requirements:
 - autoclaves and sterilizers for treatment of solid wastes need specially designed accommodation and services;
 - wastewater and sewage discharged from laboratories may have to be pretreated;
 - incinerators may need to be of special design and equipped with after burners and smoke-consuming devices.
19. Laboratories and their animal houses are occasionally the targets of vandals. Security may be augmented by strong doors, screened windows, and restricted issue of keys.

Laboratory equipment: The risk of an infection can be minimized by the use of safety laboratory equipment, practices and facilities. This section deals primarily with laboratory equipment suitable for work with Risk Group II (and also Risk Group III) agents.

The head of the laboratory, after consultation with the safety officer and safety committee, should ensure that adequate equipment is provided and that it is used properly. In selecting safe laboratory equipment, the general principles that should be considered include:

- designed to limit or prevent contact between the operators and the infectious agent;
- constructed of materials that are impermeable to liquids, corrosion-resistant, and meet structural strength requirement;
- fabricated to be free of burrs and sharp edges;
- designed, constructed and installed to facilitate simple operation and to provide for ease of maintenance, accessibility for cleaning, and ease of decontamination and certification testing.

These are general principles. Detailed performance and construction specifications may be required to ensure that the equipment purchased will possess the necessary safety features.

Recommended biosafety equipment:

1. Pipetting aids-to replace mouth pipetting. These are available in many designs.
2. Biological safety cabinets-to be used whenever:
 - Procedures with a high potential for creating hazardous aerosols are conducted. These may include centrifugation, grinding, blending, vigorous shaking or mixing, sonic disruption, opening containers of infectious materials whose internal pressure may be different from the ambient pressure, intranasal inoculation of animals, and harvesting infected tissues from animals or eggs.
 - High concentrations or large volumes of infectious agents are handled. Such materials may be centrifuged in the open laboratory if sealed heads or centrifuge safety cups are used and if they are opened only in a biological safety cabinet.
3. Loop microincinerators - to reduce aerosol production.
4. Screw-cap tubes and bottles - to provide positive specimen containment.
5. Autoclaves - to sterilize contaminated material.

Health and medical surveillance: The objectives of the health and medical surveillance of laboratory personnel are:

- to provide a means of preventing occupationally acquired disease by the exclusion of highly susceptible individuals as well as by regularly reviewing those accepted for employment;
- to provide a means for the early detection of laboratory-acquired infection;
- to assess the efficacy of protective equipment and procedures.

It is the responsibility of the employing authority through the laboratory director to ensure that health and medical surveillance of laboratory personnel is carried out.

Guidelines for the surveillance of workers handling microorganisms of Risk Group I:

These microorganisms are unlikely to cause human disease or animal disease of veterinary importance. Ideally, however, staff members should be subjected to a pre-employment health surveillance procedure regarding past medical history. Prompt reporting of illness or laboratory accident is desirable and all staff members should be made aware of the importance of maintaining good laboratory safety practice.

Guidelines for the surveillance of workers handling microorganisms of Risk Group II:

1. Pre-employment of preplacement health surveillance is necessary. This screening should include the past medical history. A clinical examination and the collection of a baseline serum sample would be advantageous and, in some cases, may be necessary.
2. The laboratory should maintain an up-to-date list of the employees' family medical practitioners.
3. Records of illness and absence should be kept by the laboratory director and it is the responsibility of the laboratory worker and his own medical adviser to keep the director informed of all absences due to illness.
4. Women of child-bearing age should be made aware, in unequivocal terms, of the risks to the unborn child of occupational exposures to microbiological agents, such as rubella and cytomegalovirus. The precise steps taken to protect the foetus will vary, depending on the microorganisms to which exposure may occur.

Training: Human error and poor laboratory practice can compromise the best of laboratory safeguards and equipment provided specifically to protect the laboratory worker. Thus, a safety-conscious staff, well informed about the recognition and control of hazards present in the laboratory, is the key element in the prevention of laboratory accidents and acquired infections. For this reason, continuous on-the-job training in safety measures is essential. The process begins and procedures are integrated into the employee's basic training. Safety measures should always be an integral part of a new employee's introduction to the laboratory.

Laboratory supervisors must play the key role in training their immediate staff in good laboratory practice. The safety officer can assist in training and with the development of training aids and publications.

Staff training should always include safe methods in dealing with the following hazardous procedures commonly encountered by all laboratory personnel:

- procedures involving inhalation risks (i.e. aerosol production)-streaking agar plates, pipetting, centrifuging, flaming loops, opening cultures;
- procedures involving ingestion risks-handling specimens, smears and cultures;
- procedures involving disposal of infectious material.

Handling, transfer and shipment of specimens: The handling, transfer and shipment of improperly packed specimens and infectious agents carries a risk of infection to all people directly engaged in, or in contact with, any part of the process. Improper handling within the laboratory endangers not only the immediate staff but also administrative, secretarial and other support personnel. Transfer of materials between laboratories or institutions widens the scope of risk to the public and to airline and postal personnel.

Internal handling procedures:

Specimens containers. Specimens containers should be leakproof. No material should remain on the outside after the cap has been closed.

Transport. To avoid accidental leakage or spillage into the environment special secondary containers should be provided for the transport of specimens between wards or departments and laboratories. These should be of metal or plastic.

Reception of specimens. Where large numbers of specimens are received a separate room should be provided for their receipt. In a small facility, this may be part of the laboratory room.

Opening of packages. Ideally, all packages received via mail or airfreight or other common carrier should be opened in a biological safety cabinet.

Shipment by mail, airfreight or other common carrier:

The United Nations Committee of Experts on the Transport of Dangerous Goods, the International Air Transport Association (IATA), the Universal Postal Union (UPU), the International Civil Aviation Organisation (ICAO) and the World Health Organisation (WHO) have developed agreed common definitions, packaging, and labeling requirements.

Definitions. The definitions adopted for application as from 1983 are as follows:

- "Infectious Substances are defined as substances containing viable microorganisms or their toxins which are known, or suspected, to cause disease in animals or humans."
- "Diagnostic Specimens are any human or animal material including, but not limited to, excreta, secreta, blood and its components, tissue and tissue fluids, being shipped for purpose of diagnosis, but excluding live infected animals."
- "Biological Products are either finished biological products for human or veterinary use manufactured in accordance with the requirements of national public health authorities and moving under special approval or license from such authorities; or finished biological products shipped prior to licensing for development or investigational purposes for use in humans or animals, or products for experimental treatment of animals, and which are manufactured in compliance with the requirements of national public health authorities. They may also cover unfinished biological products prepared in accordance with procedures of specialised government agencies. Live animal and human vaccines may be subject to authorization by the country of destination."

Packaging requirements. Packaging of infectious substances and diagnostic specimens is in three layers: (a) a primary watertight receptacle containing the specimen; (b) a secondary watertight receptacle enclosing enough absorptive material between it and the primary receptacle to absorb all of the fluid in the specimen in case of leakage; and (c) an outer package which is intended to protect the secondary package from outside influence such as physical damage and water, while in transit (Figure 1). It is important to tape securely on the outside of the secondary container one copy of the specimen data forms, letters and other information that identifies or describes the specimen. (Another copy should be sent by airmail to the receiving laboratory and a third copy retained by the sender). In this manner, the receiving laboratory can identify the specimen and make the decision regarding safe internal handling and examination.

Fig. 1



Infectious substances are classified as dangerous goods. Packages containing such substances must bear the infectious substance (biohazard) label (see Fig. 2).

The IATA Shipper's Declaration for Dangerous Goods must also be completed for shipment by either airfreight or airmail.

The Universal Postal Union (UPU) requires that containers for international shipment of noninfectious diagnostic specimens and other biologicals materials bear the standard international violet-coloured "matieres biologiques perissables" (perishable biological substances) label (see. Fig.3).

- See Part II: E. "Safe shipment of specimens and infectious substances", for additional information, including emergency actions to be followed in the event of a transport accident involving the shipment or transfer of microorganisms



Fig. 2

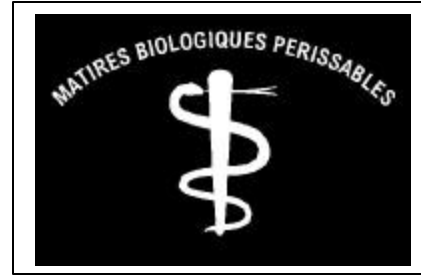

Fig. 3

Emergency procedures: Emergency contingency plans should be prepared for each individual laboratory as well as for the institutions. These are best prepared by the individual laboratory supervisor in conjunction with his staff and the safety officer. This procedure offers the best prospect of success as it is the immediate staff who are most familiar with the hazards associated with the particular laboratory.

Once the emergency plan is formulated, it should be pasted in conspicuous place in the laboratory for immediate reference.

Emergency plans should provide for:

- (a) breakage and spillage,
- (b) accidental injection, cuts and abrasions,
- (c) accidental ingestion of potentially hazardous material,
- (d) a potentially hazardous aerosol release (other than in a safety cabinet),
- (e) breakage of tubes in centrifuges not having safety cups,
- (f) fire, flood and natural disaster,
- (g) vandalism,
- (h) emergency services-whom to contact,
- (i) emergency equipment and its location.
- (j) Refer to Part II : F. "Contingency plans and emergency procedures", for further information.

Decontamination and disposal:

Decontamination and disposal in laboratories are closely interrelated acts, since disinfection or sterilization constitute the first phase of disposal. All materials and equipment will ultimately be disposed of; however, in the terms of daily use, only a portion of these will require actual removal from the laboratory or destruction. The remainder will be recycled for use within the laboratory, examples being re-usable laboratory glassware, instruments and laboratory clothing. Disposal should therefore be interpreted in the broad sense rather than in the restrictive sense of a destructive process.

The principal questions to be answered prior to disposal of any objects or materials from laboratories dealing with potentially infectious microorganisms or animal tissues are:

- Have the objects or materials been effectively disinfected or sterilised by an approved procedure?
- If not, have the objects or materials been packaged in an approved manner for immediate on-site incineration or transfer to another laboratory?
- Does disposal of the disinfected or sterilized objects or materials involve any additional potential hazard, biological or otherwise, to those carrying out the immediate procedure or those who might come into contact with the objects or materials outside the laboratory complex?

Decontamination:

Autoclaving is the procedure of choice for all decontamination processes. The autoclave should be of the gravity displacement type and worked upon at 1.4 kg/cm² pressure for 30 minutes.

Alternate methods, if an autoclave is not available include:

- boiling for 30 minutes, preferably in water containing sodium bicarbonate,
- use of a pressure cooker at the highest attainable working pressure.

Disinfectants and chemicals:

There should be a written disinfectant policy stating which disinfectants are used for what purpose and the use-dilution of each.

Sodium hypochlorite and formaldehyde are the disinfectants recommended for general laboratory use.

For special purposes phenolic compounds, various surface-active and/or lipid-destroying agents, including alcohols, iodine and iodophors and other oxidising agents, as well as very high or extremely low pH, can be effective provided that it has been established that the agent to be destroyed is not resistant to the procedure.

Other methods:

The use of dry heat is discouraged because of its unpredictable variations. Similarly, ultraviolet irradiation is unsuitable.

- See Part II : G. "Disinfection and sterilisation", for further information

Disposal:

An identification and separation system for contaminated materials (and their containers) should be established. Categories may be :

- (a) non-contaminated waste that can be disposed of with general waste,
- (b) "sharps"-needles, syringes, etc.,
- (c) contaminated material for autoclaving and recycling,
- (d) contaminated material for disposal.

"Sharps":

Hypodermic needles should be placed in containers with walls that are not readily penetrable. When full, these should be placed in contaminated waste containers and incinerated, even if laboratory practice requires that they are autoclaved first.

Disposable syringes, placed in container, should be incinerated, even if they are autoclaved first.

Contaminated material for autoclaving and recycling:

The material is placed in shallow leakproof containers containing enough of a suitable disinfectant to cover the contents. The containers are then placed in the autoclave. No precleaning is performed; any necessary cleaning or repair is done after autoclaving.

Contaminated material for disposal:

All cultures and contaminated material are normally autoclaved in leakproof containers prior to disposal. Following autoclaving the material may be placed in transfer containers for transport to the incinerator or other point of disposal.

In some situations, the autoclaving step is not required. In such instances the contaminated waste is placed in specially marked containers and transported directly to an incinerator. The best practice is to place a plastic bag

for containing the waste in a paperboard box; then contents and container can all be incinerated. If transfer containers are used they should be cleaned and disinfected after emptying the contaminated waste and prior to return to the laboratory. Such containers should be leakproof with tight-fitting covers.

Incineration:

Incineration is the method of choice for final disposal of contaminated waste, including carcasses of laboratory animals. Incineration for this purpose must meet with the approval of public health and air pollution authorities and the safety officer.

Where incinerators are not approved for such use, final disposal methods must be established in cooperation with public health authorities.

Animal facilities: The use of laboratory animals for experimental and diagnostic purposes imposes on the user the obligation to take every care to avoid causing the animals unnecessary pain or suffering. They must be provided with comfortable, hygienic housing and adequate, wholesome food and water. At the end of the experiment they should be destroyed in a humane, painless manner.

Only healthy persons should enter the animal houses. Qualified well trained animal house officers must be available.

The animal house or room should be an independent, detached unit. If it adjoins the laboratory facilities, the design should provide for its isolation from the public laboratory should such need arise.

The design and layout of the unit will vary greatly depending upon the species of animals to be accommodated, upon the nature of the work programme, and upon local climatic conditions. Individual rooms are required to separate animals according to the degree of hazard of the agents under investigation. Additional design requirements may be obtained from publications devoted to laboratory animal care.

General safety precautions:

The following safety precautions apply to the management of all facilities :

1. A change of footwear and outer clothing should be made when entering or leaving an animal unit.
2. Appropriate protective clothing and gloves should be worn when necessary.
3. Entry of wild rodents and other animals and insects must be prevented. They may carry agents pathogenic to man without themselves exhibiting any symptoms. Any such intrusion should be reported.
4. Small laboratory rodents or other animals that escape from their cages should be killed when captured and their carcasses incinerated.
5. Unexpected illness or deaths among animals should be reported without delay. Animals suffering from unexpected illness should not be touched until instructions are given by the head of the laboratory or other responsible officer.
6. The hands should be washed-thoroughly after dead or live animals have been handled.
7. Small wounds, however trivial, incurred while handling animals, must be treated immediately; bleeding should be encouraged, followed by liberal washing in soap and water; a protective first aid dressing should be applied and treatment sought as soon as possible. This applies especially if wounds are caused by animals.
8. All staff working in animals facilities should be immunized against tetanus and against other agents when indicated and available.
9. Excretion of agents in saliva, faeces and urine will contaminate the animal box and bedding. The danger of aerosol contamination is increased when soiled bedding is disturbed.
10. Inoculations and post-mortem examinations involving dangerous pathogens should be conducted in a microbiological safety cabinet.
11. Cages that have been used for work with pathogens should be autoclaved before they are cleaned.
12. All laboratory animals can be symptomless carriers of microorganisms highly dangerous to man.

13. Special precautions should be taken with drugs used for the sedation or euthanasia of experimental animals. At least one of the assistants should be aware of the emergency procedures in the event of accidental self-injection by the operator.
14. Volatile anaesthetic may affect staff in a confined space or may be explosive.

Chemical, electrical, fire, and radiation safety: A breakdown in the containment of pathogenic organisms may result indirectly through fire or chemical, electrical, or radiation accidents. It is therefore mandatory to maintain high standards of chemical, electrical, fire, and radiation safety in the microbiology laboratory.

Statutory rules and regulations for each of these will normally be laid down by the competent national or local authorities.

Their assistance and guidance should be sought if necessary. A preliminary assessment of the status of the laboratory in respect to these hazards can be made by using the safety check list give in Part II: H. "General safety checklist". *

B. The Containment Laboratory: The containment laboratory is designed and provided for work with Risk Group III agents-those that present a high risk to laboratory workers but a low risk to the community.

This level of containment requires strengthening of the basic laboratory operational and safety programmes as well as the provision of added structural safeguards and the mandatory use of biological safety cabinets.

The guidelines are presented in the form of modifications in the guidelines for the basic laboratory. Therefore, the reader must first apply the basic laboratory guidelines before those specific of containment laboratories. The major changes are in:

- Code of practice
- Laboratory design and facilities
- Health and medical surveillance

Laboratories in this category should be registered or listed with the national or other appropriate health authority.

Code of practice: The code of practice for a basic laboratory applies except where modified as follows:

1. The two-person rule should apply, whereby no individual works alone within the laboratory.
2. A hazard warning sign should be displayed on laboratory doors, identifying the agent, the name of the laboratory supervisor and other responsible person(s) and indicating any special conditions of entry into the area (immunizations, etc.) (see. Fig.4).
3. Laboratory clothing that protects street clothing (i.e. solid front or wrap-around gowns, scrub suits, coveralls, etc.) must be worn in the laboratory. Front-button laboratory coats are unsuitable. Laboratory clothing must not be worn outside the laboratory and must be decontaminated before being laundered.
4. When appropriate, respiratory protective equipment should be worn in rooms containing infected animals.

Fig. 4: Hazard warning sign for laboratory doors



BIOHAZARD

ADMITTANCE TO AUTHORIZED PERSONNEL ONLY

Hazard identity: _____

Responsible investigator: _____

In case of emergency call: _____

Daytime phone: _____ Home phone: _____

Authorization for entrance must be obtained from the Responsible Investigator named above

Laboratory design and facilities: The containment laboratory is designed for work with Risk Group III agents and with large volumes and high concentrations of Risk Group II agents, where there is a high risk of aerosol spread or infection.

The section on design and facilities for a basic laboratory applies, except where modified below :

1. The laboratory should be separated from areas that are open to unrestricted traffic flow within the building. Additional separation may be achieved by using a laboratory at the blind end of a corridor, a partition and door, a double-door system where entry to the laboratory should be through an ante-room or airlock.
2. Access to the laboratory area should be designed to prevent entrance of free-living arthropods and other vermin.
3. The surfaces of walls, floors, and ceilings should be water resistant and easy to clean. Openings in these surfaces should be sealed to facilitate decontaminating the area.
4. A foot or elbow-operated wash-hand basin should be provided near each laboratory exit door.
5. Windows in the laboratory should be closed and sealed.
6. Access doors to the laboratory should be self-closing and lockable.
7. An autoclave for decontamination of laboratory wastes should be available within the laboratory. If infectious wastes have to be removed to another area in the same building for disinfection, they should be held and transported in a covered, leakproof container.
8. There should be a ventilation system that establishes a negative pressure into the laboratory so that there is a directional air flow from the corridor or the basic laboratory to the working area of the containment laboratory. Personnel must verify that proper direction air flow (into the laboratory) is achieved.
9. The building exhaust system can be used for this purpose if the exhaust air is not recirculated to other areas of the building. Air within the laboratory can, however, be recirculated.
10. The exhaust air from the laboratory should be discharged directly to the outside or through the building exhaust system so that it is dispersed away from occupied building and air intakes. The exhaust air from the laboratory that does not come from the biological safety cabinet can be discharged to the outside without being filtered.
11. In laboratories that have supply air systems, the supply air and exhaust air systems are interlocked to ensure inward air flow at all times.

12. The HEPA-filtered exhaust air from Class I and Class II biological safety cabinets should be discharged directly to the outside or through the building exhaust system. (HEPA:high efficiency particulate air).
13. If the HEPA-filtered exhaust air from Class I or II biological safety cabinets is to be discharged to the outside through a building exhaust air system, it should be connected to this system in such a way as to avoid any interference with the air balance of the cabinet or building exhaust systems.
14. Air may be recirculated within the laboratory only after it has been filtered through tested and certified cabinet exhaust HEPA filters.
15. Exhaust air from Class III biological safety cabinets must be discharged directly to the outside without being recirculated through the laboratory.

Laboratory equipment: The principles for the selection of equipment, including biological safety cabinets, are the same as the basic laboratory except that all activities involving infectious materials are conducted in biological safety cabinets, with other physical containment devices, or using special personal protective equipment. The use of a Class III biological safety cabinets or a flexible-firm isolator may be indicated for procedures with Risk Group III microorganisms.

Health and medical surveillance: The objective of health and medical surveillance programmes for basic laboratories apply to containment laboratories, except where modified as follows:

1. Medical examination of all laboratory personnel working in the containment laboratory is mandatory. This examination should include a detailed past medical history and clinical examination.
2. A baseline serum sample should be obtained and stored for future reference.
3. Employees being treated with immunosuppressive drugs should not be employed in containment laboratories.

Following a satisfactory clinical assessment report, the examinee should be provided with the medical contact card (see Fig.5) stating that he/she is employed in a containment laboratory. It is suggested that this card should be wallet sized and it should always be carried by the holder.

NOTE: The contact persons to be entered on the front of the card would need to be agreed locally but might include the laboratory director, the medical adviser, or the biosafety officer.

Fig. 5. Medical contact card format

Front of card

FOR THE ATTENTION OF THE PHYSICIAN

THE CARD HOLDERS (Name of card holder)
 IS EMPLOYED AT(laboratory name. Address and numbers)

In the event of illness. The possibility of laboratory required infection should be considered. You are asked to contact as soon as possible one of the following:

1. (Name and telephone number)
 2. (Name and telephone number)

Date of Issue

Back of card

FOR THE ATTENTION OF THE HOLDER

**ALWAYS CARRY THIS CARD WITH YOU.
 ALWAYS SHOW IT TO AN ATTENDING PHYSICIAN**

C. The Maximum Containment Laboratory: The maximum containment laboratory is designed for work with infectious agents or experiments in microbiology that present, or are suspected to present, a high risk to both the laboratory worker and the community.

Construction and operation of a maximum containment laboratory should be preceded by intensive consultations with institutions that have experience operating a maximum containment laboratory.

Operational maximum containment laboratories should be under the control of national or other appropriate health authorities.

The principal features of a maximum containment laboratory are :

1. *Controlled access.* Entry and exit of personnel and supplies are through airlock systems. On entering, personnel put on a complete change of clothes and they shower on exit before putting on their street clothing.
2. *Controlled air system.* Negative pressure is maintained by an individual supply and exhaust air mechanical ventilation system with HEPA filters in the exhaust (and in the intake when necessary).
3. *Decontamination of effluents.* All effluents from the maximum containment laboratory are to be rendered safe, including the shower water.
4. *Sterilization of waste and materials.* A double-door pass through autoclave is provided.
5. *Primary containment.* An efficient primary containment will consist of one or more of the following:
 - a. Class III biological safety cabinet
 - b. flexible-film isolators to similar standards and
 - c. a positive-pressure ventilated suit as worn in a "suit" laboratory. In this case, a special decontamination shower must be provided for personnel leaving the suit area.

Because of the great complexity of the work a detailed work manual should be developed and tried out in training runs.

In addition, an effective emergency programme must be devised (see also Part II:F."Contingency plans and emergency procedures")*. In the preparation of this programme active cooperation with national and local health authorities should be established. Other emergency services, e.g. fire, police, receiving hospitals, should likewise be involved.

D. The Gene Technology Laboratory: There are no unique or specific safety risks associated with recombinant DNA work (genetic engineering); the risks are no greater than those associated with work with known pathogens and do not necessitate special laboratory design or practice.

An aid to the selection of suitable laboratory facilities and practices is provided in Table 1.

Table 1: Proposed safety levels for work with recombinant DNA technique*

Source of donor DNA	Disease-producing potential	Required laboratory classification
Viruses	Nonpathogenic Pathogenic	Basic Laboratory According to laboratory classification appropriate for donor organism
Prokaryotes	Nonpathogenic Pathogenic	Basic Laboratory According to laboratory classification appropriate for donor organism
Eukaryotes	Nonpathogenic/and/or no toxin production Pathogenic and/or toxin production Sequence coding for highly achieve biological substances	Basic laboratory Appropriate to the known or conjectural risks ²

* These recommendations do not preempt national guidelines or regulations.

A Work with eukaryotic infectious agents is classified according to the risk group of the donor. When other eukaryotes are used as donors and when predetermined DNA sequences that code for toxins or highly active biological substances are manipulated, the laboratory classification as to be chosen that is suitable to the known or conjectural risks. A careful assessment of these risks should be performed in consultation with the appropriate authorities and/or experts.

V. RECOMBINANT DNA SAFETY CONSIDERATIONS

A. Microorganisms

1. Classification of micro-organisms on the basis of risk groups:

Preamble: Recombinant DNA technique includes three components: the selected sequence of DNA of the Donor (any living species or even synthetic sequences), the Vector usually a virus or a plasmid (that may be endowed with the potentiality of autonomous replication) that carries the ligated donor sequences into the recipient host, and the Host, invariably a microbial cell or a cultured cell. To achieve the required biotechnological potential, manipulation of all the three components are essential. Therefore any guidelines drawn up will take into account hazards posed by all the three components, viz., the donor, the vector and the host. It is now accepted that the hazards posed in recombinant DNA technology is not more than that of the donor microorganism. Therefore in the fitness of things, for framing the guidelines, it would be appropriate to consider the classification of donor micro-organisms according to the hazard posed by it and the respective containment measures which are required to be followed.

Accidental infection of laboratory workers with pathogenic microorganisms has paralleled the entire development of the microbiological sciences. The literature is replete with accounts of these accidents. The increase in the laboratory acquired infections despite of advances in containment techniques is probably due to the volume of microbiological research; and the broadened spectrum of infectious agents under investigation. With experience gained, it is now possible to classify the microorganisms according to the risks posed by them to the handlers, and the ease of their transmission in the society.

In our classification, certain microorganisms have been classified at a higher or lower category depending upon the conditions prevalent in the country. For example, Foot and Mouth Disease virus (attenuated strain) has been assigned to lower Risk Group since the virus(es) are widely prevalent in the country. Similarly, the other pathogens widely prevalent in the country are brought under lower category of Risk Group. Some of the microorganisms not present in the country have been assigned to a special category requiring highest degree of safety, for example - Lassa virus, Yellow fever virus, etc.

Bacterial

Risk Group I

All bacterial agents not included in higher classes according to "Basis for Agent Classifications":

Risk Group II

Actinobacillus - all species except *A. mallei*, which is in Risk Group III.

Arizona hinshawii - all serotypes

Bacillus anthracis

**Bordetella* - all species

Borrelia recurrentis, *B. vincenti*

** *Cl. chauvoei*, *Cl. difficile*, *Cl. fallax*, *Cl. haemolyticum*,

Cl. histolyticum, *Cl. novii*, *Cl. perfringens*, *Cl. septicum*,

Cl.sordelii

*Corynebacterium diptheriae**, *C. equi*, *C. haemolyticum*

C. pseudotuberculosis, *C. pyogenes*, *C. renale*

Diplococcus (*Streptococcus*) *pneumoniae*

Erysipelothrix insidiosa

Escherichia coli - all enteropathogenic serotypes

Haemophilus ducreyi, *H. influenzae*, *H. pneumoniae*

Herellea vaginicola

Klebsiella-all species and all serotypes
Legionella
Leptospira interrogans - all serotypes reported in India
Listeria, all species
Mima polymorpha
Moraxella-all species
Mycobacteria-all species including *Mycobacterium avium*, *M.bovis*,
M. tuberculosis, *M.leprae**.
** *Mycoplasma*-all species except *M.mycoides* and *M.agalactiae*
Neisseria gonorrhoeae, *N. meningitidis**
Pasteurella - all species except those listed in Risk Group III.
Salmonella*- all species and all serotypes
**Shigella* - all species and all serotypes
Sphaerophorus neorophorus
Staphylococcus aureus
Streptobacillus moniliformis
Streptococcus pyogenes, *S.equi*, *S.pneumoniae**
Streptomyces madurae pelleteri somaliensis
Treponema carateum, *T.pallidum* and *T. pertenu*
**Vibrio foetus*, *V.comma* including biotype EIT or and
V. parahemolyticus
Vibrio cholerae

Risk Group III

Actinobacillus mallei
Bartonella - all species
Brucella - all species
Clostridium botulinum, *Cl. tetani**
Francisella tularensis
Mycobacterium avium, *M.bovis*, *M. tuberculosis*, *M. leprae*.
Pasteurella multocida type B ("buffalo" and other foreign virulent strains)
Pseudomonas pseudomallai
Yersinia pestis

* Cloning agents and strains for human vaccine production.

** Agents likely to be employed for recombinant work in Veterinary field.

Fungal

Risk Group I

All fungal agents not included in higher classes according to "Basis for Agent Classification"

Risk Group II

Actinomycetes (including) *Nocardia* and *Actinomyces* and *Arachina propionica*
Aspergillus fumigatus
Blastomyces dermatitidis
Cryptococcus neoformans *C. fersiminosos*
Epidermophyton madurella, *E. microsporon*
Paracoccidioides brasiliensis
(*Sporothrix Trichoderma Trichophyton*)

Risk Group II

Coccidioides immitis
Histoplasma capsulatum
Histoplasma capsulatum var duboisii

Parasitic

Risk Group I

All Parasitic agents not included in higher classes according to "Basis for Agent Classifications:."

Risk Group II

**Entamoeba histolytica*
**Leishmania species*
Naegleria gruberia
Plasmodium thcilera
Plasmodium fabetesia, P.falciparum
Schistosoma
Toxoplasma gondii
Toxocara canis
Trichinella spiralis
Trichomonas
Trypanosoma cruzi

Risk Group III

Schistosoma mansoni

Viral, Rickettsial and Chlamydial

Risk Group I

All viral, rickettsial and chlamydial agents not included in higher classes. In addition the following :

Influenza virus A/PR8/34
**Newcastle disease virus - strains licensed for vaccine use Parainfluenza Virus 3, SF4 strain
** Rinderpest - attenuated virus strain (e.g. Kabatte-O) licensed for vaccine use.

Risk Group II

Adenoviruses - Human, all types
Avian leukosis
Cache Valley virus
CELO (avian adenovirus)
Coxsackie A and B viruses
Corona viruses
Cytomegalo viruses
*Dengue virus, when used for transmission experiments
Echo viruses - all types
Encephalomyocarditis virus (EMC)
Flanders virus
Hart Park virus
*Hepatitis-associated antigen material - hepatitis A and B viruses, non A and non B, HDV Herpes viruses - except herpes virus simiae (monkey B virus) which is in Risk Group IV.
Infectious Bovine Rhinotracheitis virus (IBR).
Infectious bronchitis**
Infectious Bursal diseases of poultry.
**Infectious Laryngotracheitis (ILT)
*Influenza virus - all types, except A/PR8/34 which is in Risk Group I.
Langat virus
Leucosis complex**
Lymphogranuloma venereum agent.
**Marek's Disease virus
*Measles virus
Mumps virus
**Newcastle disease virus (other than licensed strain for vaccine use)
Parainfluenza viruses - all types except Parainfluenza virus 3, SF4 strain, which is in Risk Group I

*Polio viruses-all types, wild and attenuated
 Poxviruses - all types except Alastrim, monkey pox, sheep pox and white pox, which depending on experiments are in Risk Group III or IV.
 **Rabies virus - all strains except rabies street virus, which should be classified in Risk Group III when inoculated into carnivores
 Reoviruses - all types.
 Respiratory syncytial virus
 Rhinoviruses - all types
 Rinderpest (other than vaccine strain in use)
 Rubella virus
 Simian viruses - all types except herpes virus simiae (Monkey B Virus) which is in Risk Group IV.
 Simian virus 40
 Ad 7 SV 40 (defective)
 Sindbis virus
 Rensaw virus
 Turlock virus
 Vaccinia virus
 Varicella virus
 Vole rickettsia
 Yellow fever virus, 17D vaccine strain

Risk Group III

African Horse Sickness (Attenuated strain except animal passage)
 Alastrim, monkey pox and whotepox, when used in vitro
 Arboviruses - All strains except those in Risk Group II and IV
 Blue Tongue virus (only serotypes reported in India)
 Epstein - Barr viurs
 Feline Leukemia
 Feline sarcoma**
 Foot-and-Mouth Disease virus (all serotypes and subtypes)
 Gibbon Ape Lymphosarcoma
 Herpes virus ateles
 Herpes simplex saimiri
 Herpes simplex 2
 HIV-1 & HIV-2 and strains of SIV
 Infectious Equine Anaemia
 Lymphocytic choriomeningitis virus (LCM)
 Psittacosis-omithosis -trachoma group of agents
 Pseudorabies virus
 Rabies street virus, when used inoculations of carnivores
 Rickettsia - all species except Vole rickettsia and Coxiella burnetti when used for vector transmission.
 **Sheep pox (field strain)
 Swine Fever virus
 Vesicular stomatitis virus
 Woolly monkey Fibrosarcoma
 Yaba pox virus
 Non-defective Adeno-2SV-40 hybrids

Risk Group IV

Alastrim, monkeypox, whitepox, when used for transmission or animal inoculation experiments.
 Hemorrhagic fever agents, including Crimean hemorrhagic and
 Korean hemorrhagic fever (Congo) and others as yet undefined.
 Herpes virus simae (monkey B viurs)
 Tick-borne encephalitis virus complex, including Russian Spring
 Summer Encephalitis, Kyasanur Forest Disease, Omsk hemorrhagic fever and Central European Encephalitis viruses.

SPECIAL CATEGORY

Bacterial

Contagious Equine Metritis (*H. equigenitalis*)

Pestis peti de ruminantium

Viral, Rickettsial and Chlamydial

African Horse Sickness virus (serotypes not reported in India and challenge strains)

African Swine Fever

Bat rabies virus

Blue tongue virus (serotypes not reported in India)

Exoitic FMD virus types and sub-types Junin and Machupo viruses

Lassa virus

Marburg virus

Murrey valley encephalitis virus

Rift Valley Fever virus

Small pox virus - Archival storage and propagation

Swine Vesicular Disease

Venezuelan equine encephalitis virus - epidemic strains

Western Equine encephalitis virus

**Yellow fever virus - Wild strain,

Other Arboviruses causing epizootics and so far not recorded in India.

2. **General scientific considerations* for risk assessment of microorganisms:** Attempt is made to set out basic scientific considerations that may be relevant in assessing the possible risks associated with the use of rDNA organisms. Although the list attempts to be comprehensive as far as present knowledge allows, not all the points included will apply to every case. It is to be expected therefore that individual proposals will address only those issues that are relevant to the proposed work. The level of detail required is also likely to vary according to the nature of the proposal.

A. Characteristics of Donor and Recipient Organisms

1. *Taxonomy, identification, source, culture*
 - a. Name and designations.
 - b. The degree of relatedness between the donor and recipient organisms and evidence indicating exchange of genetic material by natural means.
 - c. Characteristics of the organism which permit identification and the methods used to identify the organisms.
 - d. Techniques employed in the laboratory and/or environment for detecting the presence of, and for monitoring, numbers of the organisms.
 - e. The sources of the organisms.
 - f. Information on the recipient organisms's reproductive cycle (sexual/asexual).
 - g. Factors which might limit the reproduction, growth and survival of the recipient organism.
2. *Genetic Characteristics of donor and recipient organisms*
 - a. History of prior genetic manipulation
 - b. Characterisation of the recipient and donor genomes.
 - c. Stability of recipient organism in terms of relevant genetic traits.
3. *Pathogenic and physiological traits for donor and recipient Organisms*
 - a. Nature of pathogenicity and virulence, infectivity, or toxicity.
 - b. Host range
 - c. Other potentially significant physiological traits.
 - d. Stability of these traits

B. Character of the Modified Organism

- a) Description of the modification
- b) The nature, function and source of the inserted donor nucleic acid, including regulatory or other elements affecting the function of the DNA and of the vector.
- c) The method(s) by which the vector with insert(s) has been constructed.
- d) Method(s) for introducing the vector-insert into the recipient organism and the procedure for selection of the modified organism.
- e) The structure and amount of any vector and/or donor nucleic acid remaining in the final construction of the modified organism.
- f) Characterisation of the site of modification of the recipient genome. Stability of the inserted DNA.
- g) Frequency of mobilization of inserted vector and/or genetic transfer capability

* Genetic Manipulation Advisory Group Medical Research Council : ACGM/HSE/ Note-3

C. Expression and properties of the gene product

- a) Rate and level of expression of the introduced genetic material. Method and sensitivity of method.
- b) Activity of the expressed protein.
- c) Allergenic hazard of the product.
- d) Toxic hazard of the product.

3. **Host/Vector systems:** Host/Vector Systems are three categories, normal (10^{-3}), disabled and especially disabled. Disabled and especially disabled host/vectors have an access factor of 10^6 and 10^9 respectively. Use of these vectors, naturally brings down the physical containment level.

Criteria for disabled host/vector system: The disabled host/vector systems listed are based on the following considerations, which are given here to assist investigators who may wish to generate new vectors or to adapt or modify existing ones.

In general, vectors must be safe not only to human-beings but also to domestic animals. There should not be any neoplastic effect.

Bacterial plasmid based cloning systems

1. Plasmids must not be self transmissible.
2. Non mobilisable or only very inefficiently mobilisable. These plasmids should not code for the mobilisation proteins and also must be deficient in nic site on which the mobilisation proteins act. Such plasmids have an access factor of 10^6 even on normal *E. coli* host.

Bacteriophage lambda based cloning systems

1. Must have reduced host range, achieved by the incorporation of amber mutations (reversion frequency 10^{-5} or less) in two different genes not involved in lysis.
2. Must be non lysogenic; achieved by deletion of phage attachment site and defective repressor (CI) gene.
3. Must not propagate in the plasmid mode.
4. If the repressor is temperature sensitive, the host strains must be rec A mutants.
5. If a lysogenic phage vector is used then the host must be disabled, like *E.coli* strains DP50 Sup F or MRCl.

M13 vector systems

1. F-factor in the host must be defective for mobilisation.
2. Vector must have amber mutations in at least two genes.

- i) Host-Vector systems for *Bacillus subtilis*
 HVI Host strains: RUB 331, BGSC 1S53, BD224, PSL1, CU403.
 Plasmids: pUB110, pC194, pS194, pPSA2100, pEI94, pBD15 (pEI94) cop6 pT127, pC221, pC223, pAB124 and their recombinant derivatives e.g. pBD9, pBD12.
 HV2 Host strains: Aspergenic strain ASB298
 Plasmids : pUB110, pC194, pS194, pSA2100, pEI94, pBD15 pT127, pUB112, pC221, pC223, pAB124, pBD9, pBD12, etc.
- ii) *Escherichia coli* K12:
 Vectors for *E.coli*
 pAA31; pNo 1523; pSCC31; pGA22; pLG338; pBEU43; pKN402; pBR312; pBR313; pBR315; pBR320; pBR322; pBR325 pBR327; pKT21; pKTH605 pMC 1871; pMK20; pUc5; pUc3; pUc4; pUc6; pUc7; pUc8; pUc9; pUR2, pWR4.
- iii) Bacteriophage:
 Vectors for bacteriophage M13
 M13mp7; ml3Gori 1
 λ1059; λ1127; λ2001; Charon 4; Charon 4A; Charon 10; Charon 27; Charon 28; Charon 34; λEMBL3; λEMBL4; λgt10; λgtii, lgtWES; λB; λNM607; Homer I; pEMBLB; pCP3; pLC28; pBN37; pWT571; pOP203-1; pEX1; pKH4; pKT241; ptac11; pKO4; λ21; pEP74.
- iv) *E.coli* K12/*S. cerevisiae* hybrid systems:
 Yeast *E.coli* shuttle vectors
 YIpl, YIp5, YEp4, YEp13, YEp24, YEp135, YRp7, YRp12, Yrp17, YCpR1, pAH5, pAH9, pMA301, pMAC561, pAAR6, pMC2010, YEp6.
- v) Plasmid Vectors for cloning DNA in *Streptomyces*

Vector	Copy No.	Size, KB	Parent replicon	Markers
*pIJ61	5	14.8	SLP1.2	Ltz ⁺ <u>tsr aphI</u>
*pIJ 486/487	100	6.2	PIJ101	tsr <u>neo</u>
*pIJ 702	100	5.8	PIJ101	tsr mel
pIJ 941	1	25.0	SCP2*	Ltz ⁺ <u>tsr hyg</u>
pMS 63	100	5.0	PIJ101	tsr <u>aph</u>
pSK 21-K3	20	8.0	PSK2	Tsr
pSW1	5	16.6	PSG2	<u>tsr cat</u>
pVE30	High	7.7	PVE1	sr <u>vph amp</u>
pIJ922	1	24	SCP2	Tsr, Ltz
Phage Vectors				
*KC515	—	φ 38.6	C31	<u>vph, tsr</u>
KC 684	—	φ 40.5	C31	<u>tsr lac Z</u>
PM8	—	φ 39.3	C31	<u>tsr hyg fd ter</u>
TG78	—	φ 38.8	TG1	Tsr

* often used

- vi) *Pseudomonas putida*

HVI Strain KT 2440
 Plasmids pKT 262, 263 and 264

- vii) Host-vector systems for *Haemophilus* (Mainly for self-cloning work).

Strains : *Haemophilus influenzae* Rd
Haemophilus parainfluenzae (rough strain)

Plasmids : pRSF0885 and its derivatives

- pJI-8
- pDM2
- pJI-8 nov^r str^r 44

viii) Vectors for DNA transfers through *Agrobacterium*

Binary vectors (To be used in combination with any Ti plasmid containing vir genes.)

1. pRAL 3940
2. pCEL 44
3. pGA 471

Receptor and intermediate vectors

1. pGV 3850
pLGV 1103
2. pTiB6S3SE
pMon200

Vectors for *H. influenzae* Rd and *H. parainfluenzae*

- RSF 0885
- pJI-8
- pDM 2

Binary vectors: Ti plasmids regions carrying the T-DNA and the vir loci can be physically separated while remaining functionally intact. T-DNA inserted into Ti-independent replicons for the *Agrobacterium* chromosome) is transferred to the plant with the help of vir functions provided in trans as efficiently as T-DNA physically linked to the vir-loci in cis.

The new generation of Binary Vectors are based on this principles:

S. No.	Vectors	References
1.	Vehicle PAL 1050 used with plasmid pAL 4404	Hoekema <i>et. al.</i> Nature 303 (1983) 179-80
2.	Vehicle 13 and 19 used with plasmids pAL 4404	Bevan, Nucleic Acids Res., 12 (1984) 8711-8721
3.	Vehicle pGA 436 or 437 or 438 used with plasmid pTi A 6 or pTi 37	An <i>et al.</i> EMBO J. 4(1985)
4.	Vehicle pPCV 310 or pPCV 311 used with plasmid pMP 90 RK.	Czaba & Schell Mol. Gen. Genetics 204 (1986) 383-396
5.	Vehicle Micro Ti: pRK used with plasmid pTi B6-806	de Framond <i>et al.</i> Mol. Gen. 202 (1986) 125-131.

Cointegrate Vectors: Foreign genes carried by pBR-like intermediate vectors are transferred from *E.coli* into *A. tumefaciens* and recombined into acceptor Ti plasmids by cointegrate formation involving a single cross-over between homologous pBR sequences of the Ti plasmid and the intermediate vector.

S. No.	Vectors	References
1.	Vehicle pMON 120. Cocultivation with pTiB 653	Fraley <i>et al</i> PNAS 80 (1983) 4803-4807
2.	Vehicle pNo1, Cocultivation with pTi C58	Herrera-Estrella <i>et al.</i> Nature 303 (1983) 209-231
3.	i) Vehicle pGV 3850 cocultivation with pTiB 653 ii) Vehicle pGV 831 cocultivation with pGV 2260.	Deblaere <i>et al.</i> Nucleic Acids Res. 12(1985) 4777-4788

A. Information about vectors in relation to *Agrobacterium*

1. Shuttle vectors for cloning *Agrobacterium* genes:
pTJS140, pUCD2, pUCD4, pUCD9p, pSa4, pVCK102 (Cosmid) and pHK17 (Cosmid.)
2. Plasmid with vir genes: pTVK25

3. Vectors for gene transfer:
 - a. Based on pBR322 - pLGV2381, pGV3850
 - b. Minivector - pRAL3940
 - c. Requiring *vir* genes in *trans* - pAL1050
 - d. Split end vector system - pTiB6S3SE and pMON200
 - e. Broad host range vector systems-pKan1, pKan1a, pZein6a & 8a

B. Information about vectors in relation to *E.coli*

1. Vectors for cloning:

S. No.	Vector type	Name of Vector
1.	Lambda phage based	Lambda gt 10, Lambda Charon 4A and Lambda EMBL3
2.	Transmid vector	pRRA101
3.	Cosmid vector	pHC79, pDZCos 2, pLAFRI (Broad host range)
4.	Broad host range	pRK290, pSUP106, pVK102, pRK325 cloning vectors
5.	Other cloning vectors	pBR322, pBR325, pBR327, pBR328, pNG16, pCED6, pMK2004, pKT231, pUr222, pACYC177, pACYC184, pNC874 pSUP106, pKO1, pUC7, pUC8, pUC9, pUC13, pUC18, pUC19, pUCD2, pUCD4
6.	Broad host range expression vectors	pNM185
7.	Expression vectors	pRL31, pKK223-3, pPLC236, pATH2, pTR262

2. Vectors for sequencing:

pVH51, pCB221, M13mp7, mp8, mp9, mp11, mp18 and mp19.

Details of Host Vector Systems in Cyanobacteria

S. No.	Recombinant plasmid	Cyanobacterial plasmid & host	Construction of recombinant plasmid	Function of the recombinant plasmid
1.	PDF30 (14Rb,9.33MD) Amp ^r , Cam ^r	pDF3, <i>Anacystis nidulans</i> 6311	pDF3+pBR325 transforms both <i>E.coli</i>	Shuttle vector <i>A. nidulans</i> and
2.	pUC104 (12.2kb,8.13Md) Amp ^r , Cam ^r	pUH24 <i>A.nidulans</i> RZ	pUC1(deletion derivative of a pUH24:: Tn901 plasmid	Shuttle vector transforms both <i>A.nidulans</i> and <i>E.coli</i>
3.	pAQE2 (8.8kb,5.9Md) Amp ^r	pAQ1 <i>Aqmenellum quadruplicatum</i> PR-6	pAQ1+pBR322	Shuttle vector transforms both <i>A. quadruplicatum</i> and <i>E.coli</i>
4.	pAQE10 (10.3kb, 6.9Md) Amp ^r , Cam ^r	"	pAQ1+pBR325	"
5.	pGL4 (8.8kb, 5.9Md) Amp ^r , Cam ^r	pGL2 <i>Nostoc</i> PCC6705	pGL2+pBR328	Hybridplasmid maintained in <i>E.coli</i>
6.	pGL5 (6.3kb, 4.25Md) Amp ^r , Cam ^r	pGL3 <i>Plectonema</i> PCC6306	pGL3+pBR328	"
7.	pRL1 (9.26kb,6.17Md) Cam ^r	pDU1 <i>Nostoc</i> PC7524	pDU1+pBR322 +Cam ^r fragment from pBR328	Shuttle vector capable of conjugative transfer from <i>E.coli</i> to <i>Anabaena</i> and transforms <i>E.coli</i>
8.	pRL5 (11.1kb,7.4Md) Cam ^r , Sm ^r	pDU1 <i>Nostoc</i> PCC7524	pDU1+pBR322 +Cam ^r fragment from pBR328+ Sm ^r fragment from R300B	Shuttle vector capable of conjugative transfer from <i>E.coli</i> to <i>Anabaena</i> and transforms <i>E.coli</i>
9.	pRL6 (11.3kb,7.53Md) Cam ^r ,Km ^r ,Mm ^r	PDU1 <i>Nostoc</i> PCC752	pDU1+pBR322 fragment from pBR38+ Km ^r fragment of Tn5	Shuttle vector capable of conjugative transfer from <i>E.coli</i> to <i>Anabaena</i> and transforms <i>E.coli</i>
10.	pSp8 (5.7kb, 3.8Md) Amp ^r	0.95Md plasmid from <i>P.boryanum</i> plasmid UTEX954	<i>P. boryanum</i> +pBR322	Hybrid plasmid maintained in <i>E.coli</i>

Disabled *E.coli* host vectors**

S. No.	VECTOR	HOST	ACCESS FACTOR
1.	Plasmids pAT153, pACYC184	Especially disabled strains of <i>E.coli</i> K12 ie MRC 1,7,8,9 x1776	10 ⁻⁹
2.	pAT153, pACYC184	<i>E.coli</i> K12	10 ⁻⁶
3.	pUC series	<i>E.coli</i> K12	10 ⁻⁶
4.	pBR322, pSC101	Recombination deficient strains of <i>E.coli</i> K12	10 ⁻⁶
5.	<i>mob</i> ⁻ derivatives of Inc F,P,Q,W and X group plasmids	Especially disabled strains of <i>E.coli</i> K12	10 ⁻⁹
6.	<i>mob</i> ⁻ derivatives of Inc F,P,Q,W and X group plasmids	<i>E.coli</i> K12	10 ⁻⁶

For reference, the following plasmids which were listed individually in GMAG Note 9 and supplements can be assigned Access Factors as follows:

S. No.	VECTOR	HOST	ACCESS FACTOR
1.	pBR313, pMB9, pAC134 pWT111, pWT121, pWT131,	Recombination deficient strains of <i>E.coli</i> K 12	10 ⁻⁶
2.	pOP213-13, pOP95-15		
3.	pBR327, pBR328, pWT211, pWT221, pWT231	Especially disabled strains of <i>E.coli</i> K12	

2. Bacteriophage lambda based vectors

S. No.	VECTOR	HOST	ACCESS FACTOR
1.	λgt WES. λB λgt VirJZ.3 λ B λgt WES. T5-622	With <i>recA</i> ⁻ strains of <i>E. coli</i> K 12	10 ⁻⁶
2.	λCharon 3 A λCharon 4 A t NM788 λCharon 24A λ1059	With any strain of <i>E.coli</i> K12	10 ⁻⁶

3. M13 Vectors (with nonsense mutations)

1.	M13 Mp 2 am4	JM101 (tra D36)	10 ⁻⁶
2.	M13 Mp 73	JM103	10 ⁻⁶

4. Cosmid Vectors

1.	pJC74, pJC79, pFF2	<i>E.coli</i> K12	10 ⁻⁶
2.	Homer I	MRC8	10 ⁻⁹

** Genetic Manipulation Advisory Group, Medical Research Council GMAG NOTE-14.

Disabled yeast host/vector systems

5. The following *Saccharomyces cerevisiae* vectors when used in conjunction with standard *S. cerevisiae* host strains have been accepted as having an Access Factor of 10⁻⁶ provided that the vector's foreign sequences come from the listed vectors.

5.1 a bacterial plasmid or a bacteriophage vector in which a selectable yeast nuclear gene has been inserted (such vectors do not replicate autonomously in yeast but can integrate by homology into yeast nuclear DNA);

- 5.2 a bacterial plasmid or a bacteriophage vector in which has been inserted a segment of yeast nuclear DNA that contains a selectable function and which is also able to replicate in yeast (such vectors may integrate by homology into yeast nuclear DNA or remain free as an autonomous replicon with a single copy per yeast cell).
- 5.3 a bacterial plasmid or a bacteriophage vector in which has been inserted the yeast '2 micron' plasmid and a selectable yeast nuclear gene (such vectors integrate by homology into yeast nuclear DNA).
6. The *S.cerevisiae* host strains SHY 1,2,3 have been accepted as having an Access Factor of 10^9 when used in conjunction with any of the *S. cerevisiae* vectors referred to above.

NB When any of the above *S. cerevisiae/E.coli* chimaeric vectors are grown in *E.coli* hosts the access factor should be based solely on the bacterial components of the systems.

***Bacillus subtilis* host/vector systems**

7. ACGM considers that proven asporogenic mutant derivatives of *B. subtilis*, with the following plasmids as vectors warrant an Access Factor of 10^6 - pUB110, pC194, pS194, pSA2100, pE194, pT127, pUB112, pC221, pC223 and pAB124.

4. **Strains for self cloning experiments:** Self cloning experiments using the strains given below are exempted from notification:

A. Prokaryotes

1. *E. coli* K12 and other well characterised non-pathogenic laboratory strains of *E.coli*.
2. *Bacillus subtilis*.
3. *Bacillus stearothermophilus*
4. *Bacillus thuringiensis*.
5. Non pathogenic strains of *Streptomyces*
6. Nonpathogenic strains of *Micromonospora*
7. Strains of *Nocardia mediterranei*.
8. *Klebsiella pneumoniae* strain M 5 al.
9. *Acremonium chrysogenum*
10. *Pencillium chrysogenum*.
11. Non-pathogenic strains of *Haemophilus*.

B. Eukaryotes

1. *Saccharomyces cerevisiae*
2. *Neurospora crassa* with selected vectors.
3. Mouse cells with polyoma virus.

C. Strains with shuttle vectors

E. coli K12 carrying recombinant plasmids constructed in

- i. *Klebsiella pneumoniae* M5 al.
- ii. *Saccharomyces cerevisiae*
- iii. *Streptomyces*
- iv. *Haemophilus*
- v. *Bacillus*

5. **Gene Exchanger Classification:** The Gene Exchanger classification is mostly adopted from NIH guidelines. In the case of organisms covered under the list on various subgroups appropriate containment levels must be followed as per guidelines:

Subgroup A: Generally included *Escherichia*, *Shigella*, *Salmonella*, *Enterobacter*, *Citrobacter*, *Klebsiella*, *Erwinia*, *Pseudomonas* (*P.aeruginosa* *P. putida* and *P. fluorescense*), *Serratia marcescenes*, *Yervinia entrocalitica*.

Subgroup B: *Bacillus subtilis*, *B. licheniformis*, *B. pumilus*, *B. globigii* *B. niger*, *B. nato*, *B. amyloliquefaciens*, *B. atterimus*.

Subgroup C: *Streptomyces aureofaciens*, *S. rimosus*, *S. coelicolor*

Subgroup D: *Streptomyces griseus*, *S. cyaneus*, *S. venezuelae*

Subgroup E: One way transfer of *S. mutans* or *S. lactics* DNA into *S. sanguis*

Subgroup F: *Streptococcus sanguis*, *S. pneumoniae*, *S. faecalis*, *S. pyogenes* and *S. mutans*

Subgroup G: *Haemophilus influenzae* Rd and *H. parainfluenzae* R strain

Subgroup H: *Agrobacterium tumefaciens* and *Rhizobium* certain species

6. Toxin classification

- I. LD50 less than 100 ng/kg body weight
Botulinum, tetanus, diptheria, *Shigella dysenteriae* neurotoxin (Cloning of these toxins genes are prohibited).
- II. LD50 less than 100 µg (but more than 100 ng/kg body wt.) (Genes falling in this range can be cloned)
 - i) LD50 100-1000 ng/kg body wt. includes abrin. *Clostridium perfringens* epsilon toxin (P2+BC2) or (P3 + BC1)
 - ii) LD50 1µg-100 µg (P1 + BC1)

Under the guidelines cloning of *Staphylococcus aureus* alpha and beta toxins. *B. pertussis* toxin, cholera toxin and the heat labile toxin of *E. coli* in organisms other than *E. coli* are subject to prior review.

7. Categorisation scheme based on risk assessment*

The values prescribed are all probabilities per unit bacterium, a value of 1 means all bacteria are expected to have access, express a polypeptide or cause some biological damage. 10^{-3} means a chance of this occurring is 1 in thousand bacteria.

1. Access factor

The probability of entry and survival of the manipulated organism, in the target tissue/cell if they escape by chance.

Table below illustrate the calculated figures or established systems.

Organism	Access factor
Wild type <i>E.coli</i> (enterobacterium)	1
<i>E.coli</i> K12 or similar lab strains (normal)	10^{-3} =BC1
Disabled host/vector systems	10^{-6} =BC2
Non mobilisable vector in disabled host	10^{-9} >BC2
Genetically manipulated DNA in tissue culture cells. This DNA cannot infect by itself	10^{-12}

2. Expression factor

Probability of translation of the gene in the manipulated organism and secretion of the cloned gene product from the altered organism

Following table lists calculated factors for certain DNAs.

DNA cloned specifically for its expression	1
cDNA from which expression is not sought deliberately	10^{-3}
Genetic DNA in a known plasmid	10^{-3}
DNA whose non-expression is clearly demonstrated	10^{-6}
Genetic DNA in non-expression sites	10^{-6}

* Genetic Manipulation Advisory Group Medical Research Council GMAG Note -14

3. **Damage factor:** The probability that the expressed product cause physiological damage to the individual. Only approximations are possible here. DNA molecules both singly stranded and double stranded may not survive in individuals. Regarding proteins before assigning a factor one should show its effect in animal systems.

Damage factor for certain specific cases

Expression of toxic or a biologically active substance in quantities large enough to have significant biological effect.	1
Expression of Biologically active substance in quantities large enough to cause serious deleterious effect if it were delivered and completely absorbed at the target tissue	10^3
Expression of biologically active substances at levels lower than that of the normal body level	10^6
Expression of proteins which do not have any biological effect or of substances which already exist in large quantities.	10^9

Assignment Risk category must be done taking all the three factors access, expression and damage together into consideration.

Example

S. No.	Damage	Access	Expression Risk	Calculated	Category
1.	Hormones Toxins and host	Disabled	+	10^6	III / IV
	Biologically active polypeptides or		+	10^9	II
	Polypeptides which enhance pathogenicity of host organism		-	10^{12}	I
2.	Uncharacterised <i>E.coli</i> K12		+	10^6	III
	polypeptides of unknown		+	10^6	II
	Biological functions		-	10^{12}	I
3.	Uncharacterised disabled		+	10^9	II
	polypeptides of host				
	unknown		+	10^{12}	I
	Biological function		-	10^{12}	I

A comprehensive listing could be prepared with the available data from the literature. Further the Principal Investigator should make every effort to furnish this data based on scientific forethought to IBSC in case his/her experiments are not classifiable with the available information.

Category I: Experiments in category I need not be reviewed by the IBSC.

Category II: Proposals must be submitted in suitable format in order to review by the IBSC. Format given at the end.

Category III & IV: Unlike Category II experiments, Category III & IV experiments must be cleared by the IBSC before commencement.

B. Large Scale Operations

1. Physical Containment Conditions For Large-Scale (20L) Fermentation Experiments And Production

- A. Cultures of viable organisms containing recombinant DNA molecules shall be handled in a closed system (e.g. closed vessel used for the propagation and growth of cultures) or other primary containment equipment (e.g. biological safety cabinet containing a centrifuge used to process culture fluids) which is designed to reduce the potential for escape of viable organisms.
- B. Cultures fluid shall not be removed from a closed system or other primary containment equipment unless the viable organism containing recombinant DNA molecules have been inactivated by a validated inactivation procedure. A validated inactivation procedure is one which has been demonstrated to be effective using the organism that will serve as the host for propagating the recombinant DNA molecules.

- C. Sample collection from a closed system, the addition of materials to a closed system and the transfer of culture fluids from one closed system to another shall be done in a manner which minimises the release of aerosols and contamination of exposed surfaces.
- D. Exhaust gases removed from a closed system or other primary containment equipment shall be treated by filters which have efficiencies equivalent to HEPA filters or by others equivalent procedures (e.g. incineration) to minimise the release of viable organisms containing recombinant DNA molecules to the environment.
- E. A closed system or other primary containment equipment that has viable organisms containing recombinant DNA molecules shall not be opened for maintenance or other purposes unless it has been sterilised by a validated sterilisation procedure. A validated sterilisation procedure is one which has been demonstrated to be effective using the organism that will serve as the host for propagating the recombinant DNA molecules.
- F. Emergency plans as and when required shall include methods and procedures for handling large losses of cultures on an emergency basis as recommended by IBSC and approved by the competent authority.

2. Criteria For rDNA GLSP Micro-organisms ***

Host Organism	rDNA Organism	Vector/Insert
Non-Pathogenic	Non-Pathogenic	Well characterised and free from known harmful sequence
No adventitious Agents	As safe in industrial setting as host organism, but with limited survival without adverse consequence in environment	Limited in size as much as possible to the DNA required to perform the intended function; should not increase the stability of the construct in the environment (unless that is a requirement of the intended function)
Extended history of safe industrial use, OR		Should not transfer any resistance markers
Built-in environmental limitations permitting optimal growth in industrial setting but limited survival without adverse consequences in environment		Should not transfer any resistance markers to micro-organisms not known to acquire them naturally (if such acquisition could compromise use of drug to control disease agents)

*** Genetic Manipulation Advisory Group,
Medical Research Council: ACGM/HSE/Note-3

- 3. Use of rDNA Technology in Vaccine Development:** The issue of licenses for the manufacture of genetically engineered vaccine need to be considered only when the recommended facilities for the category or the organism in question is provided for an inspected physically by the competent authority.

For large scale fermentation experiment and production (20 litres capacity) four levels of containment as mentioned in Chapter II would be applicable. Important thing is to use a closed system.

However following review of the IBSC of appropriate data for a particular host-vector system more latitude in the application of the guidelines may be permitted.

Experiments exempt from guidelines:

1. Self cloning experiments (except in Risk Group II and above)
2. Experiments involving DNA from bacteria within an exchanger sub-group as recommended by WHO. This shows proposed safety levels for work with rDNA techniques, only the non-pathogenic organisms mentioned are exempt.
3. Experiments involving *E.coli* K12, *Saccharomyces cerevisiae* *Bacillus subtilis* and *Streptomyces lividans* recommended host vector system are exempt from guidelines except those utilising DNA

of etiologic agents from Risk Group II and above, requiring case by case approval, or cloning of toxin genes (producing LD50 at less than 50 ug/kg. of body weight of vertebrates) or large scale growing.

Experiments covered under the guidelines

Experiments not falling within the ambits of above exemptions would require adherence to the general guidelines. As a rule, DNA of a donor agent falling within a particular risk group (say II) will require facilities pertaining to next higher group agents (risk group III). However, the exact requirements would be decided by the IBSC on a case by case basis. A few examples of cloning agents and strains for human vaccine production using new technology are given in Chapter V: A1. See Asterik(*).

A list of genes that are currently being cloned, likely to be cloned in the veterinary field in India has to be continually updated. This list should include all the cell vectors, infective and non-infective agents likely to be employed for recombinant DNA technology work (Chapter V:A1. See Asterik (**). In these cases, the risk classification has to conform to the standards laid down in the guidelines.

List of Cells With Various Characteristics And Levels Of Concern About Their Use As Substrates

A. CELL LINE	CHARACTERISTICS				
	Life span	Chromosomes	Tumorigenicity	Risk Group	Containment
Fibroblasts (WI-38)	Finite	diploid	Negative	0	P ₀
Continuous				1	
Kidney (VERO)	Infinite	Abnormal	Negative	2	P ₂
Tumour (Hela)	Infinite	Abnormal	Progressive	4	P ₃
BHK-21	Infinite	Abnormal	Progressive	3	P ₂

4. **The Quality Control of Biologicals Produced by Recombinant Technology:** Now we are just at the beginning at the manufacturing scale and the present experience may not be adequate to control problems which may be encountered. Therefore, the proposed requirement for controlling the safety, purity and potency of the biological products produced by Recombinant DNA Technology must be regarded as flexible and subject to change as experience of the manufacturers and use of such products increases.

The control proposals: The control of biologicals produced by Recombinant DNA methods, the following topics are of concern:

1. Molecular identity of product,
2. Biological potency,
3. Purity,
4. Toxicity,
5. Immunogenicity
6. Consistency of production.

Starting Material: A description of the host cell and of the expression vector used in the production and an explanation of the measures used to promote and regulate the expression of the cloned gene will be expected.

Expression System: Recombinant DNA technology involves a process of systematically arranging and manipulating the nucleic acid segments to produce a novel molecule which is then placed into an appropriate host system/environment which would yield a desired product. Therefore, the manufacturer should provide a description of:

- (i) The method used to prepare the segment coding for desired product including the cell type and origin of source material, detailed nucleotide sequence analysis and restriction enzyme digestion map of the cloned segments including the additional sequences if present. In addition, the information on the construction of the vector used for expression of the cloned nucleotide segments into its respective product should also be thoroughly described.
- (ii) The restriction enzyme digestion map of the entire constructed vector should also be provided.

- (iii) The host cell system which has been utilised for generating the product for the expression host should also be provided including its source, phenotype, genotype etc.
- (iv) Cloning history and methodology should also be described.
- (v) The information of the new masters cell bank, if any, are to be provided by the manufacturing unit.

Master Cell Bank: The host cell chosen for the expression of the Recombinant DNA products should be maintained as a seed bank, in seedlots in order to ensure genetic stability of the host cell utilised. The purity of the cell in the seedlot should be assured by isoenzyme analysis, auxotrophy, antibiotic resistance and karyology as appropriate.

Manufacturing Products: Details of fermentation of culture used in the manufacture of the product will be required. Test for microbial contamination should be carried out and the information about the sensitivity of the methods used to detect contaminants, provided. Details of methods used to purify the gene product and the efficacy of the purification used, to remove host cell polypeptides etc., and other impurity, demonstrated.

Purification: The methodology for harvesting, extracting and purification should be described in detail and removal of any toxic chemicals produced by this procedure should also be demonstrated. The extent of purification of DNA recombinant products should be consistent with the intended use of the product. The purification process should eliminate specifically, detectable viruses, nucleic acid or non target antigenic material present in it.

Characterisation of the Product: The evidence of purity of the product should be established and the identity of the product with the reference preparation should be derived from the wider variety of tests available. The tests may include the following:

- A.
 - (1) Composition analysis of amino acid.
 - (2) Partial sequences analysis
 - (3) Peptide mapping
 - (4) Polyacrylamide gel electrophoresis (PAGE) and iso electric focussing (IEF).
 - (5) High performance liquid chromatography (HPLC) etc.
 - (6) Other characterisation.
- B. Biological test for identity and potency.
- C. Tests for contaminations.
 - (1) Pyrogen contamination,
 - (2) Viral contamination,
 - (3) Nucleic acid contamination,
 - (4) Antigen contamination,
 - (5) Microbial contamination.
- D. Toxicity test and analysis: A recombinant DNA product demonstrated to be identical to naturally occurring substance for which pharmacological and toxicological data exists at the doses levels intended for use, then they are not to be developed. The data will be required for the product which are developed having minor modification in their chemical and physico-chemical characteristics. The product, with radically altered chemical structure from natural substance would require an elaborate animal tests including those for carcinogenicity, teratogenicity, effects on fertility etc. The specific tests which might be appropriate are best addressed on a case by case basis with the appropriate authority.

Clinical Trial: Clinical trails will be necessary for all products derived from DNA technology to evaluate their safety and efficacy. The efficacy of each biological must be proven for license by biometrically significant immunogenicity test in each host animal species. Five replicate potency tests must be conducted according to the outlines and geometrical average must be taken for the host vaccine. Challenge immunogenicity tests in a significant number of animals to establish biostatistically significant proof of margin for efficacy. The testing of these new product should be undertaken in the controlled environment and evaluated carefully before their release to the market under license. The testing of the product should be bound by the guidelines already available for handling of the Recombinant DNA products.

Control of Final Product: The toxicity of the Recombinant DNA derived product, which deviates in any way from its natural counterpart or entirely a novel molecule, is likely to require more extensive investigation, on a case by case basis.

C. **Plants and Agriculture**

The application of genetic engineering to agriculture is directed to deliver products whose research, evaluation and commercial use would require studies on introduction into the field. These products include genetically engineered plants, microbes, animal vaccines and animals.

Many of the scientific considerations described in earlier chapter are relevant to plants and animals derived by rDNA techniques. Additionally, the general considerations (Chapter V) describing the significance of the donor, recipient and modified organisms are also essential to safety assessment evaluation.

The proposed regulation requires a permit for the introduction of any "regulated article" which is defined as "any organism or product which has been altered or produced through genetic engineering, if the donor organism, recipient organism, or vector or vector agent" is specifically listed in the regulation or which is determined by the competent agency as a plant pest/pathogen that cause disease to plants. The proposed regulated articles are grouped by class, order, genus, family and other groupings.

1. **Organisms, Pests that cause diseases to Plants**

The taxa or group of organisms which are or contains plant pest are listed. Organisms belonging to all lower Taxa contained within the group listed are also included.

1. *Virus*

All members of groups containing plant viruses, and all other plant and insect viruses.

The following viruses are subject to quarantine also

Bean Yellow Mosaic (Pea strain)

Pea Early Browning

Pea Enation

Cowpea Mottle

Cowpea Mild Mottle

Cowpea Severe Mosaic

Cowpea Yellow Mosaic

Cowpea Ringspot

Soybean stunt

Cucumber Mosaic

(soybean strain & other)

Tobacco Ring spot

(Soyabean strain)

Tobacco Streak

(Soyabean strain)

Tomato Ringspot

Bean Pod Mottle

Soybean Mild Mottle

Soybean stunt

Cowpea Mild Mottle

Cacao Necrosis Virus

(Soybean strain)

Pea Seed-brown Mosaic

Cucumber Mosaic

(Green gram strain)

Black gram mottle

Bean Yellow Mosaic

(Green gram strain)

Cucumber Mosaic

(Groundnut strain)

Peanut stripe

Peanut stunt

Marginal Chlorosis

Cowpea Mottle

(Bambara groundnut strain)

Special Case

Nuclear Polyhedrosis Virus

Cytoplasmic Polyhedrosis Virus

Granular Virus-Baculo

Geminiviruses

Caulimoviruses

2. Bacteria

Bacillus *thuringiensis*

Bacillus *sphaericus*

Genus *Pseudomonas*

Genus *Xanthomonas*

Genus *Azotobacter*

Genus *Rhizobium*/*Azorhizobium*

Genus *Bradyrhizobium*

Genus *Agrobacterium*

Genus *Phyllobacterium*

Genus *Erwinia*

Genus *Enterobacter*

Genus *Klebsiella*

Genus *Azospirillum*

Genus *Acquispirillum*

Genus *Oceanospirillum*

Genus *Streptomyces*

Genus *Nocardia*

Genus *Actinomyces*

Coryneform group

Genus *Clavibacter*

Genus *Arthrobacter*

Genus *Curtobacterium*

Genus *Bdellovibrio*

Rickettsial - like organisms associated with insect diseases

Gram-negative phloem-limited bacteria associated with plant diseases

Gram-negative xylem-limited bacteria associated with plant diseases.

Genus *Spiroplasma*

Mycoplasma - like organisms associated with plant diseases

Mycoplasma - like organisms associated with insect diseases.

3. Algae

Family Chlorophyceae

Family Euglenophyceae

Family Pyrophyceae

Family Chrysophyceae

Family Phaeophyceae

Family Rhodophyceae

4. Fungi

Family Plasmodiophoraceae

Family Chytridiaceae

Family Hypochytridiaceae

Family Olpidiopsidaceae

Family Synchytriaceae

Family Catenariaceae

Family Coelomomycetaceae

Family Saprolegniaceae

Family Zoopagaceae

Family Albuginaceae

Family Peronosporaceae

Family Pythiaceae

Family Leptolegnielleaceae

Family Mucoraceae

Family Choanephoraceae

Family Mortierellaceae

Family Endogonaceae

Family Syncephalastraceae

Family Dimargaritaceae

Family Eurotiaceae

Family Ophiostomataceae

Family Ascosphaeraceae

Family Onygeneaceae

Family Microascaceae

Family Erysiphaceae

Family Meliolaceae

Family Xylariaceae

Family Diaporthaceae

Family Hypocreaceae

Family Clavicipitaceae

Family Phacidiaceae

Family Ascocorticiaceae

Family Hemiphacidiaceae

Family Dermataceae

Family Sclerotiniaceae

Family Cytrariaceae

Family Helotiaceae

Family Kickxellaceae
 Family Saksenaaceae
 Family Entomophthoraceae
 Family Ecerinaceae
 Family Protomycetaceae
 Family Taphrinaceae
 Family Endomycetaceae
 Family Saccharomycetaceae
 Family Elsinoeaceae
 Family Myriangiaceae
 Family Dothideaceae
 Family Chaetothyriaceae
 Family Parmulariaceae
 Family Phillipsiellaceae
 Family Hysteriaceae
 Family Pleosporaceae
 Family Melanomataceae
 Family Sacrosomataceae
 Family Sarcoscyphaceae
 Family Auriculariaceae
 Family Ceratobasidiaceae
 Family Corticiaceae
 Family Hymenochaetaceae
 Family Echinodontiaceae
 Family Fistulinaceae
 Family Clavariaceae
 Family Polyporaceae
 Family Tricholomataceae
 Family Ustilaginaceae
 Family Sporobolomycetaceae
 Family Uredinaceae
 Family Agaricaceae
 Family Graphiolaceae
 Family Pucciniaceae
 Family Melampsoraceae

Family Ganodeniatiaceae
 Family Laboulbeniaceae
 Family Sphaeropsidaceae
 Family Melanconiaceae
 Family Tuberculariaceae
 Family Dematiaceae
 Family Moniliaceae
 Family Agonomycetaceae

5. Protozoa

Genus Phytomonas
 And all Protozoa associated with insected diseases

6. Nematodes

Family Anguinidae
 Family Belonolaimidae
 Family Caloosiidae
 Family Criconematidae
 Family Dolichodoridae
 Family Fergusobiidae
 Family Hemicycliophoridae
 Family Heteroderidae
 Family Hoplolaimidae
 Family Meloidogynidae
 Family Neotylenchidae
 Family Nothotylenchidae
 Family Paratylenchidae
 Family Tylenchidae
 Family Tylenchulidae
 Family Adhelenchoididae
 Family Longidoridae
 Family Trichodoridae

7. *Mollusca*

Superfamily Planorbacea
Superfamily Achatinaceae
Superfamily Arionaceae
Superfamily Limacacea
Superfamily Helicacea
Superfamily Veronicellacea

8. *Arthropoda*

Superfamily Ascoidea
Superfamily Dermanyssoidea
Superfamily Eriohyoidea
Superfamily Tetranychoidae
Superfamily Eupodoidea
Superfamily Erythraenoidea
Superfamily Trombidioidea
Superfamily Hydryphantoidea
Superfamily Tarsonemoidea
Superfamily Hydryphantoidea
Superfamily Tarsonemoidea
Superfamily Pyemotoidea
Superfamily Hemisarcoptoidea
Superfamily Acaroidea
Order Polydesmida
Family Sminthoridae
Family Forticulidae
Order Isoptera
Order Thysanoptera
Family Acrididae
Family Gryllidae
Family Cryllacrididae
Family Cryllotalpidae
Family Phasmatidae
Family Ronaleidae
Family Tettigoniidae
Family Tetrigidae
Family Thaumastocoridae
Superfamily Piesmatoidea
Superfamily Lygaeoidea
Superfamily Idiostoloidea
Superfamily Coreoidea
Superfamily Pentatomoidea
Superfamily Pyrrhocoroidea
Superfamily Tingoidea
Superfamily Miroidea
Order Homoptera
Family Anobiidae
Family Apionidae
Family Anthribidae
Family Bostrichidae
Family Brentidae
Family Bruchidae
Family Buprestidae
Family Byturidae
Family Cantharidae
Family Carabidae
Family Cerambycidae
Family Chrysomelidae
Subfamily Epilachninae
Family Curculionidae
Family Torymidae
Family Xylocopidae

Family Dermestidae
Family Elateridae
Genus Helophorous
Family Lyctidae
Family Melodidae
Family Mordellidae
Subfamily Melolonthinae
Subfamily Rutelinae
Subfamily Cetoniinae
Subfamily Dynastinae
Family Scolytidae
Family Seblytidae
Order Lepidoptera
Family Agromyzidae
Family Anthomyiidae
Family Cecidomyiidae
Family Chloropidae
Family Ephydriidae
Family Lonchaeidae
Family Muscidae
Family Otitidae
Family Syrphidae
Family Tephritidae
Family Apidae
Family Caphidae
Family Chalcidae
Family Cynipidae
Family Eurytomidae
Family Formicidae
Family Psilidae
Family Siricidae
Family Tenthredinidae

SPECIAL CATEGORY

Some Major Diseases of Plants Not Yet Recorded in India

Crop	Disease	Pathogen	
Apple, Pear	Fire Blight	<i>Erwinia amylovors</i>	
Apple, Cedar	Rust	<i>Cymnosporangium juniperi Virginiae</i>	
Barley, Rye & other Gramineae	Scald or leaf Blotch	<i>Rhynchosporius secalis</i>	
Barley	Snow mould	<i>Fusarium nivale</i>	
	Leaf spot	<i>Drechslera buchloes</i>	
	Halo spot	<i>Selenophoma donacis</i>	
	Leaf spot	<i>Septoria passerinii</i>	
	Sterility Disease	<i>Pyrenophora semeniperda</i> (<i>Drechslera verticillata</i>)	
	Take All	<i>Ophiobolus graminis</i>	
	Bunt	<i>Tilletia pancicii</i>	
	Dwarf bunt	<i>Tilletia contraversa</i>	
	Basal glume rot	<i>Pseudomonas atrofaciens</i>	
	Bean, Soybean	Bacterial wilt	<i>Corynebacterium flaccumfaciens</i>
	Cassava	Brown streak	Virus
Cucumber	Bacterial wilt	<i>Erwinia tracheiphila</i>	
Date Palm	Fusarirose or Bayoud	<i>Fusarium oxysporus f.sp. albedinis</i>	
Maize	Seedling and Foot rot	<i>Marasmius graminum</i>	
	Wilt	<i>Erwinia stewartii</i>	
	Yellow leaf blight	<i>Phyllosticta maydis</i>	
	Eye spot	<i>Kabatiella zae</i>	
	Freckeled wilt	<i>Corynebacterium nebraskensis</i>	
	Oats	Halo blight	<i>Pseudomonas coronafaciens</i>
Oilpalm	Snow mould	<i>Micronectriella nivalis</i>	
	Wilt	<i>Fusarium oxysporum f. sp. elacidis</i>	
Rice	Hoja Blanca	Virus	
Rye grass & other Gramineae	Blind Seed Disease	<i>Gloeotinia temulenta</i>	
Strawberry	Red stele, Brown core, root rot	<i>Phytophthora fragariae</i>	
Sugarcane	Fiji disease	Virus	
	Streak disease	Virus	
Sunflower	Downy mildew	<i>Plasmopara halstedii</i>	
Soybean	Downy mildew	<i>Peronospora manshurica</i>	
Tobacco	Blue mould	<i>Peronospora tabacina</i>	
Wheat	Take all	<i>Ophiobolus graminis</i>	
	Eye spot	<i>Cercospora herpotrichoides</i>	
	Sterility disease	<i>Pyrenophora semeniperda</i> (<i>Drechslera verticillata</i>)	
	Halo spot	<i>Selenophoma donacis</i>	
	Dwarf bunt	<i>Tilletia contraversa</i>	
	Yellow Slime	<i>Corynebacterium siranicum</i>	

2. Genetic Manipulation of Plants and Plant Pathogens

The experiments that include:

- a) The introduction of foreign nucleic acid into plants.
- b) The introduction of foreign nucleic acid into any plant pathogen where pathogen is defined as "any living organism, other than a vertebrate animal which is injurious to any plant, and includes any culture of such organism."

Notification: Plant experiments that do not involve plant pathogen may, where appropriate be initiated once notification has been given to IBSC.

All experiments involving the genetic manipulation of plant pathogens and the use of such genetically manipulated plant pathogens will require approval of IBSC. Use of pathogenic vectors is mainly two : (i) *Agrobacterium tumefaciens* and (ii) Cauliflower Mosaic Virus.

Agrobacterium tumefaciens is used so routinely that it must be considered analogous to *E.coli* K12. Apart from transfer of *B. thuringiensis* toxin gene to plants, a new class of experiments, involves transfer of sequences from plant viruses which impart their resistance to plants to infection of these viruses (e.g. Tobacco Mosaic Virus, Alfalfa Mosaic Virus etc.) Testing to this should be in a glasshouse. As much of information as possible should be provided about the pathogen including its host range, mode of dispersal and pathogenicity. Isolated plasmids from plant pathogens are not normally considered as pathogen per se, so that transformation of plant cells by isolated plasmids of plant pathogens would not normally require approval. The genetic manipulation of microbes (including plant pathogens) are adequately covered by the existing rDNA guidelines.

- 1. Plant Experiments with no plant pathogens:** The growth of whole plants will, however require special environmental conditions which may be achieved by using glasshouse containment.

Glasshouse Containment A is appropriate to plant experiments involving no plant pathogens and would be suitable for experiments involving non-pathogen DNA vector systems and regeneration from single cells. The minimal requirements for Glasshouses Containment A are :

- Plants should be grown in a designated glasshouse or compartment, clearly marked with a bio-hazard sign indicating "glasshouse containment A".
- Any other plants grown in the designated glasshouse or compartment must be handled under conditions appropriate for the experimental plans.
- Plants should be managed by suitably trained personnel with the principles of good glasshouse hygiene.
- The IBSC should consider whether any additional factors such as pest control, screening to prevent ingress by vermin, birds and insects and destruction of surplus plants and seed are relevant to the particular experiment.

- 2. Plant Experimentation involving Plant Pathogens:** Prior approval for laboratory experiments involving genetically manipulated plant pathogens, such as the production of manipulated DNA vector systems for the transformation of cultured plant cells will normally be needed on the basis of containment categorisation.

Glasshouse Containment B is appropriate for glasshouse experiments involving (i) genetically manipulated plant pathogens including plant viruses such as the propagation of genetically manipulated organism in plants and (ii) the growth of plants regenerated from cell transformed by genetically manipulated pathogen vector systems which will still contain the pathogen.

Glasshouse containment B conditions will be specified by the Committee (RCGM) and will vary with the pathogen, being particularly dependant on its mode of dispersal, host range and pathogenicity and they are to be worked out on case by case basis.

Special conditions may be needed in addition to those given under 'A' to prevent dissemination of the genetically manipulated plant pathogen especially during transfer between glasshouse and laboratory, during disposal of plants and equipment and through survival of pollen, seeds or other biological vectors.

- Need for negative pressure and air filtration double doors etc. in cases where airborne dispersal is a potential hazard.
- Need for effluent treatment plant where water borne dispersal is a hazard.
- Need for suitable construction of glasshouse (floors, dwarf wall, threshold at door etc.) in cases where waterborne or soil borne dispersal are potential hazards.
- Need to prevent pollination and seeding, or to contain pollen and seed in cases where pollen and seed-borne dispersal is a potential hazard.
- Need for measures either to prevent contamination of, or to decontaminate the clothing of personnel or tools, pots, equipment etc., where mechanical transmissions is an above average hazard.

- f) Need to limit the growing of host plants in the vicinity of the containment facility and to provide monitoring for escape.

Inspection of a 'Glasshouse Containment B' facility by IBSC will be required before approval.

3. Pre-release tests of genetically engineered organisms on Agricultural Applications

Safety concerns focus on whether environmental and agricultural applications of organisms modified by rDNA technique pose an incremental risk. While at this time, the assessment of risk rests primarily on extrapolations from experiences with

- (i) the introduction of naturally occurring organisms to eco-systems to which they are not native
- (ii) evolution of novel traits in existing populations and
- (iii) manipulations of agricultural crops and plant-associated microbes.

No adverse consequences were noted on introduction of naturally occurring species, or the selected species evolved for agricultural applications. In analogy, it is expected that the impact on application of rDNA organism may be low as modified organism have greater predictability compared to species evolved by traditional techniques. The assessment may be conducted in small field trials upon clearance of GEAC as to those done with the introduction of selective species into the eco-system.

I. Rhizobium

(A) Strains improved by transfer of genes between rhizobia.

Conventional tests should be sufficient. These may include the following.

- (i) Elucidation of genetic markers and host range and requirements for vegetative growth.
- (ii) Effectivity tests using corresponding legume varieties under the variety of conditions to which host legume gets exposed in growth chamber and pot culture.
- (iii) Tests on persistence and stability using isolated small plots.
- (iv) Same as in (ii) in experimental field plots, for two years.
- (v) Trials in farmer fields.

The strain to be released should be highly specific, competitive and stable unless it has been produced for a special need.

(B) Strains improved by transfer of genes from heterologous nonpathogenic bacteria.

- (a) Use of foreign genes in *Agrobacterium*.
 - (i) Tests to ensure that the strain is not tumour inducing and does not transform in host-cells.
 - (ii) Other test like in (A) above.
- (b) When source of foreign genes is a non-Rhizobian prokaryote such as *Escherichia coli*
 - (i) Tests for enteropathogenicity on selected animals.
 - (ii) Other tests like in (A) above.

II. Bacteria manipulated by any method should satisfy the following:

- (a) The manipulated microorganisms should be tested for pathogenicity against its intended associative partner and also other crop plants.
- (b) They should not eliminate useful microorganisms like VA-Mycorrhizae. Suitable testing should be done in this regard before releasing a manipulated organism.
- (c) The microorganism should not stimulate unwanted plants like weeds.

III. Blue Green Algae:

All the tests as given in A and B will be applicable except that rice will be the plant against which beneficial effects of concerned algal strain will be tested.

IV. Crop Plants:

When the improved plant has been derived by transfer of genes by DNA technique from wild species or a different organism, tests on the food product and residual presence of agents toxic to man, cattle and other animals must be done.

4. Bio-Hazard Evaluation of Viral, Bacterial, Insecticidal Agents For Large Scale Application:

World Health Organisation (WHO) has developed programmes for evaluation, testing and safe use of insecticides to control vector borne diseases of public health, veterinary and agriculture importance (WHO TRS 634). The criteria (Bull. WHO (1971), 44, 11-22) for assessment of the ecological impact involves controlled testing and evaluation under field conditions. There are growing number of tested and accepted biological insect control agents belonging to diverse group such as bacteria, fungi and certain viruses etc. Some of them are registered in global market.

Any attempt at genetically altering, improving changing the host range, target specificity, differential pathogen toxicity, toxic agent productivity, factors affecting safety and efficacy, new formulations leading to newer uses of these biological control agents and related organisms and their products derived through genetic alteration would require the application of rDNA safety guidelines and regulations as per categorisation scheme worked out based on risk assessment levels.

Whereas the testing and large scale use of biological control agents would itself require the normal course of approval from Directorate of Plant Protection and quarantine under Ministry of Agriculture, the production testing and use of these genetically altered agents would be strictly governed by the rDNA guidelines and regulations of the Government of India. Violations and non-compliance including non-reporting of the R&D work in this area would attract the punitive actions provided under the Environmental Protection Act.

Bacterial Agents: Three main groups of bacteria, viz. *Bacillus popilliae*, *B.thuringiensis* and *B. sphaericus* have been subject of extensive studies. Of these, *B.thuringiensis* particularly H-14 strain has been found to be most promising for the control of larvae of lepidoptera, mosquitoes and black flies. The protein crystal toxin (δ endotoxin) of these bacilli acts as potent gut poison on ingestion by the larvae.

The development of new mutants of *B. thuringiensis* (including the asporogenic strain) producing the same toxin would not require additional safety evaluation. However, a strain producing modified toxin, possibly with altered biological activity, would require some additional evaluation of the live microorganisms and fully safety evaluation of the toxin. When the toxin-producing gene is transferred to another microorganism complete safety evaluation would be required.

Insect viruses as control agents: Virus diseases have been reported from more than 800 species of insects and mites. Major groups of virus pathogens of insects are being currently studied as control agents for pests. Insect viruses for pest (i-vi) are produced on an industrial scale.

- i) *Heliothis zea*
- ii) *H. virescens*
- iii) *Lymantria dispar*
- iv) *Neodiprion sertifer*
- v) *Orgyia pseudot-sugata*
- vi) *Dendrolimus*

The bio-hazard evaluation of promising viral agents which are naturally occurring entomopathogens should include the following:

- Elaborate tests conducted in the laboratory as well as under green-house conditions to understand potential physiological and/or genetical hazards for non-target organisms. The overall response of a species is likely to be polygenic.
- In stable ecosystems, where the potential of the viruses can be utilised most effectively, more information is required on the relationships between host density and susceptibility, virus production, persistence and transmission. Analytical approaches provide powerful ways of highlighting the importance of such factors in virus epizootiology.

- The safety measures for large-scale application of such products would require very careful evaluation since the combination of two or more types of biocides may affect the non-target organisms particularly those which are beneficial. For example genus *Apis* which plays an important role in pollination of oil seeds, legumes, vegetables, forage and food crops.
- The characteristics of baculovirus that is more useful for identification is the profile produced by cleavage of the viral DNA with bacterial restriction endonucleases. Such techniques should be used to screen all production batches which should be preferably purified before release. These batches should also be examined for the presence of other 'occluded' or 'non-occluded' viruses.
- Bacteriological check and other safety tests as mentioned in the WHO guidelines are also needed.
- The purified virus should then be formulated in such a way that its stability both on the shelf and field is satisfactory.
- The biological activity of the propagation should be measured by reproducible and effective bio-assays to measure the responses in standard activity units which can be related to the activity of the other batch.
- The application of viruses can be most effective in those areas, where there is a good understanding of the ecology of the host-virus system. The most appropriate method of 'oryctes' virus introduction, was appreciated when the effects of virus replication on larvae and adults had been extensively studied. It is probable that alternative methods of virus introduction, such as the release of infected host, would become advantageous over other methods.

Recombinant Insect viruses: *Autographa californica* nuclear polyhedrosis virus (AcNPV) is a registered insecticide in USA and is also now gaining importance for being employed as recombinant vector. The recombinant technology could be extended to the construction of novel AcNPVs with genes of *B.thuringiensis* δ -endotoxin and insect neuropeptides for greater effectiveness.

Thus baculovirus recombinant vector containing δ -toxin of *B. thuringiensis* and insect neuropeptides could be of immense use in planning overall strategy for insect control. Such products having multiple insect control features needs to be carefully assessed for the risk to the health and environment before it is licensed.

D. Environment

1. Risk Assessment Factors On Environmental Release Of Genetically Manipulated Organisms*

The following factors should be taken into account when initial local risk assessment is being made. These factors are essentially a list of points to aid the initial local risk assessment. It is not expected that for any particular release proposal all the points will be relevant. Submission of proposal for consideration by GEAC should include the objectives of the project and should consist in the main of information corresponding to the following points where they are relevant to a particular proposal. The extent of the information to be provided will depend on the type of organism and release proposed.

General: Under this heading risk assessment should, where relevant, take into account :

1. The nature of the organism or the agent to be released, in the species (or culture), its host range and pathogenicity (if any) to man, animals, plants or micro-organisms.
2. The procedure used to introduce the genetic modification.
3. The nature of any altered nucleic acid and its source, its intended function/purpose and the extent to which it has been characterised.
4. Verification of the genetic structure of the novel organism.
5. Genetic stability of the novel organism.
6. Effects that the manipulation may be predicted to have on the behaviour of the organism in its natural habitat.
7. The ability of the organism to form long-term survival forms, e.g. spores, seeds etc. and the effect the altered nucleic acid may have on this ability.
8. Details of any target biota (e.g. pest in the case of a pest control agent); known effects of non-manipulated organism and predicted effects of manipulated organism.

*ACGM/HSE/NOTE6

Release to the Environment: Information on the nature, method and magnitude of the release is important in assessing potential risk. The following points should be considered:

1. Geographical location, size and nature of the site of release and, physical and biological proximity to man and other significant biota. In the case of plants, proximity to plants which might be cross pollinated.
2. Details of the target ecosystem, and the predicted effects of release on that ecosystem.
3. Method and amount of release, rate frequency and duration of application.
4. Monitoring capabilities and intentions; how many novel organism be traced e.g. to measure effectiveness of application.
5. On-site worker safety procedures and facilities.
6. Contingency plans in event of unanticipated effects of novel organism.

Survival and Dissemination: The survival, persistence and dissemination of a released novel organism clearly has a major bearing on environmental consequences. This is especially so if the organism persists beyond the time required for its intended purpose. To evaluate this aspect, the following points should be considered:

1. Growth and survival characteristics of the host organism and the effect the manipulation may have.
2. Susceptibility to temperature, humidity, dessication, UV etc, and ecological stresses.
3. Details of any modification to the organism designed to effect its ability to survive and to transfer genetic material.
4. Potential for transfer of inserted DNA to other organisms including methods for monitoring survival and transfer.
5. Methods to control or eliminate any superfluous organism or nucleic acid surviving in the environment or possibly in a product.

CHECK LIST

It is suggested that various processes and procedures can be assessed qualitatively by means of a check list, for according approval to a laboratory for carrying out recombinant DNA technology work. The check list suggested are as follows:

1. Locality:
 - Urban
 - Rural
2. Proximity to susceptible stock
 - which stock, specify
3. Restricted public access
 - Fenced
 - Guarded
 - Locks
4. Staff Identification
 - Staff movement restrictions
5. Safety against
 - Flood
 - Subsidence
 - Landslide
 - Earthquake
 - Other
6. Is there room for development
 - Specify with diagram
7. Building
 - Generally suitable
 - Old
 - New
 - Conventional/Prefabricated/Other
 - Windows
 - Double
 - Sealed
 - Shatter proof
 - Doors
 - Self closing
 - Interlocked at airlocks
 - Vision panel
 - Marked sign -HAZARDS
 - Walls
 - Suitable surfaces
 - Floors
 - Cleanable
 - Ceiling
 - Sealed entry of services
 - Lighting
 - As per requirement
8. Laboratory fittings:
 - Benches
 - Surfaces
 - Impervious
 - Continuous
 - Safety equipments
 - Microbiological safety Cabinets
 - Class 1
 - Class 2
 - Class 3
 - Protected centrifuges
 - Protected sonicators
 - Protected homogenisers
 - Tapes
 - Hand
 - Wrist
 - Foot
 - Electronic
 - Space
 - Adequate
 - Overcrowded
9. Ventilation: Infective agent handling area
 - Air pressure
 - Negative to atmosphere
 - Negative pressure

	- Monitoring	Manometers - Frequency observation - Recording - Electronic - Temperature control humidity
	- Air locks	- Sophisticated - Simple - Separately vent ilated
	- Exhaust air	-H.E.P.A. filters Single Double Quality of Filter - Monitoring - Testing methods
	- Filter Container	- Ledder frame Canisters
	- Input air	- Filtered - Quality - Temperature, etc.
	- Input/Extract	- Interlocked
	- Stand by Generating System	- Specify capacity etc.
10.	Range of work	- Research - Vaccine production - Large animal work - Small animal work - Diagnosis - Other
11.	Effluent treatment	- Heat - Chemical - Irradiation - Other
12.	Storage of infective material	- Location - Minus 20°c - Minus 70°c - Liquid Nitrogen - Locked - Upto date records - Secure area
13.	Pass-out facilities	- Autoclaves - Fumigation cabinets - Monitoring - Photocopying - Facsimile machine
14.	Structure-Disease Security Department	
15.	Disease Security Regulations	
16.	Other Security	
17.	Fire precautions	
18.	Staff training	
19.	Staff selection	
20.	Visitors regulations	
21.	Procedures and provisions for emergencies	

N. B. : The Check List has been prepared keeping in view the standard requirement of P1 to Pa laboratories.